



# ALDERHOLT MEADOWS, DORSET

## DESIGN CODE



ALDERHOLT MEADOWS

TABLE OF CONTENTS

SECTION 1 - BACKGROUND TO THE CODE .....	2
1.1. Flow Chart - Design Evolution .....	3
1.2. Design Vision .....	5
1.3. Design Code Principles .....	5
1.4. Design Team .....	6
1.5. Purpose of the Design Code .....	7
1.6. Managing the Design Process .....	8
1.7. Mechanisms for Delivering Quality .....	8
1.8. Preparing the Design Code .....	8
1.9. Structure of the Code .....	9
1.10. Design Code Vision .....	10
1.11. Delivering the Project .....	10
1.12. Flexibility .....	10
1.13. Overall Character Strategy and Description .....	11
SECTION 2 – LOCAL HERITAGE REFERENCE – AREA ANALYSIS .....	12
2.1. Vernacular Housing Character .....	12
2.2. Conservation Area Appraisals .....	13
2.2.1. Cranborne Village .....	14
2.2.2. Cranborne Conservation Area Analysis .....	15
2.2.3. Cranborne Spatial Event .....	16
2.2.4. Cranborne Key Buildings .....	17

2.2.5. Cranborne Key Design Elements .....	18
2.2.6. Edmondsham Village .....	19
2.2.7. Edmondsham Conservation Area Analysis .....	20
2.2.8. Edmondsham Spatial Event .....	21
2.2.9. Edmondsham Key Buildings .....	22
2.2.10. Edmondsham Key Design Elements .....	23
2.2.11. Gussage All Saints Village .....	24
2.2.12. Gussage All Saints Conservation Area Analysis .....	25
2.2.13. Gussage All Saints Spatial Event .....	26
2.2.14. Gussage All Saints Key Buildings .....	27
2.2.15. Gussage All Saints Vernacular Architecture .....	28
2.2.16. Gussage All Saints Key Design Elements .....	29
2.2.17. Horton Village .....	30
2.2.18. Horton Conservation Area Analysis .....	31
2.2.19. Horton Spatial Event .....	32
2.2.20. Horton Key Buildings .....	33
2.2.21. Horton Key Design Elements .....	34
2.2.22. Wimborne St Giles Village .....	35
2.2.23. Wimborne St Giles Conservation Area Analysis .....	36
2.2.24. Wimborne St Giles Spatial Event .....	37

2.2.25. Wimborne St Giles Key Buildings .....	38
2.2.26. Wimborne St Giles Vernacular Architecture .....	39
2.2.27. Wimborne St Giles Key Design Elements .....	40
2.2.28. Alderholt .....	41
2.2.29. Alderholt Analysis .....	42
2.2.30. Alderholt Vernacular Architecture .....	43
<b>SECTION 3 - CONSTRAINTS AND OPPORTUNITIES .....</b>	<b>44</b>
3.1. Constraints and Opportunities – Infrastructure .....	45
3.2. Constraints and Opportunities – Landscape and Ecology .....	46
3.3. Overall Constraints and Opportunities Analysis .....	47
<b>SECTION 4 – INDICATIVE MASTERPLAN .....</b>	<b>48</b>
4.1. The Masterplan .....	48
4.1.1. Genesis .....	48
4.1.2. Finalising the Masterplan .....	48
4.2. Masterplan Principles .....	48
4.3. Parameters Plan - As Detailed in the Design and Access Statement .....	49
4.4. Indicative Land Use Plan .....	50
4.5. Indicative Density Plan .....	51
4.6. Block Structure and Green Infrastructure .....	52
4.7. Indicative Masterplan .....	53

4.8. Indicative Masterplan - Local Centre .....	54
4.9. Indicative Masterplan - Employment Land .....	55
4.10. Key Buildings and Key Frontages .....	56
4.11. Morphological Study .....	57
<b>SECTION 5 – LANDSCAPE STRATEGY .....</b>	<b>58</b>
5.1. Landscape Objectives .....	58
5.1.1. A Connected Landscape .....	58
5.1.2. Enhancing Biodiversity .....	58
5.1.3. A Healthy Landscape .....	58
5.1.4. Sense of Place .....	58
5.1.5. A Beautiful Place .....	58
5.2. Landscape Strategy Plan .....	59
5.3. A Beautiful Place .....	60
5.4. Approach to Landscape Design .....	61
5.5. Planting Design .....	62
5.6. Amenity Planting .....	63
5.7. Urban Wildlife Strategy .....	63
5.8. Landscape and Visual Impact Summary .....	64
5.9. Structural Trees .....	66
<b>SECTION 6 – STREETS AND MOVEMENT .....</b>	<b>67</b>
6.1. Principles and Definitions .....	67

6.2. Street Hierarchy .....	67	8.6.6. Composition of Mass .....	86
6.2.1. The Street Hierarchy Comprises: .....	67	8.6.7. Element of Contrast .....	87
6.2.2. Car Parking .....	67	8.6.8. Overall Building Heights (m) and Eaves Height (m) .....	88
6.3. Street Hierarchy Plan .....	68	8.6.9. Boundaries .....	89
6.4. Principles and Definitions – Street Hierarchy .....	69	8.7. Materials/Details .....	90
6.5. Typical Street Sections .....	70	8.8. Material Palette .....	91
<b>SECTION 7 – LIGHTING STRATEGY VISION .....</b>	<b>76</b>	8.9. Roofs .....	94
7.1. General .....	76	8.10. Design Componentry .....	95
7.2. Lighting Hierarchy .....	76	8.11. External Walls and Roof Materials - Full Palette - Proposed Material Schedule .....	96
<b>SECTION 8 – APPEARANCE .....</b>	<b>79</b>	8.12. Indicative House Types Using Local Vernacular- 2, 3, 4 & 5 Bed Mix .....	97
8.1. Building .....	79	8.13. Key Plan of the Cameo Views .....	102
8.2. Building Definitions .....	79	8.14. Key Plan of the Cameo Views 1 & 2 .....	103
8.3. Detached .....	80	8.15. Key Place 1 .....	104
8.4. Semi-detached .....	80	8.16. Key Place 2 .....	105
8.5. Terraced .....	80	8.17. Key Plan of the Cameo View 3 .....	106
8.6. Plan Form .....	81	8.18. Key Place 3 .....	107
8.6.1. Detached Plan Forms .....	81	8.19. Key Plan of the Cameo View 4 .....	108
8.6.2. Semi-detached plan forms .....	82	8.20. Key Place 4 .....	109
8.6.3. Terraced plan forms .....	83	8.21. Key Plan of the Cameo View 5 .....	110
8.6.4. Roof Forms .....	84	8.22. Key Place 5 .....	111
8.6.5. Roof Forms - Detail .....	85	8.23. Key Plan of the Cameo View 6 .....	112
		8.24. Key Place 6 .....	113
		8.25. Key Plan of the Cameo View 5 .....	114

8.26. Key Place 7 .....	115
SECTION 9 - CONCLUSION .....	116

Extract from CABE 'Design & Access Statement' Guide:

*(Similar colour coding is used for this document content for ease of reference/comparison)*

**The process**  
How the physical characteristics of the scheme have been informed by a rigorous process which should include the following steps:

- assessment
- involvement
- evaluation
- design.

**Use**  
What buildings and spaces will be used for.

**Amount**  
How much would be built on the site.

**Layout**  
How the buildings and public and private spaces will be arranged on the site, and the relationship between them and the buildings and spaces around the site.

**Scale**  
How big the buildings and spaces would be (their height, width and length).

**Landscaping**  
How open spaces will be treated to enhance and protect the character of a place.

**Appearance**  
What the building and spaces will look like, for example, building materials and architectural details.

## Access

The statement needs to include two potential aspects of access. That is not to say they are separate, and the statement should show that all access issues have been considered together.

**Vehicular and transport links**  
Why the access points and routes have been chosen, and how the site responds to road layout and public transport provision.

**Inclusive access**  
How everyone can get to and move through the place on equal terms regardless of age, disability, ethnicity or social grouping.

Some points of this CABE model are included in the DAS, with detail added in this appendix code

SECTION 1 - BACKGROUND TO THE CODE

This Design Vision document has been prepared by the Alderholt Meadows design team on behalf of the Dudson Homes (Southern) Ltd. to guide the development of the site for residential purposes.

This document has been prepared to provide detail of design and placemaking principles that demonstrate cognition of the local vernacular, and which can be used to inform each phase of the comprehensive design and creation of the new development at Alderholt village. This document is assembled as a design vision which seeks to extract the essential qualities which might feature in a fully committed design proposal for this site, and as each phase emerges as a part of the masterplan. Such that the character of place and narrative will have a full synergy with the local vernacular.

Within the body of this document, there are a number of guiding principles and proposals for analysis of the local vernacular to support a contextually driven design response. The intention is not to stifle creativity or fix designs but to allow design to be organic and of the highest quality simultaneously.

This document includes references of local architecture, key features, craft, their componentry, details and associated architectural investment, such that any subsequent application will sustain the same level of design quality, architectural design and detail. Reflecting key features of local identity, architecture, materials and spatial sensations.

An indicative masterplan layout has been prepared to fix the morphology, extent of amenity, relationship of architectural forms and their scale, as well as parking. The layout fixes certain principles and the intent to create a high-quality residential / mixed use development. A development that is born of its place and the wider county architectural setting, in lieu of a more generic approach.

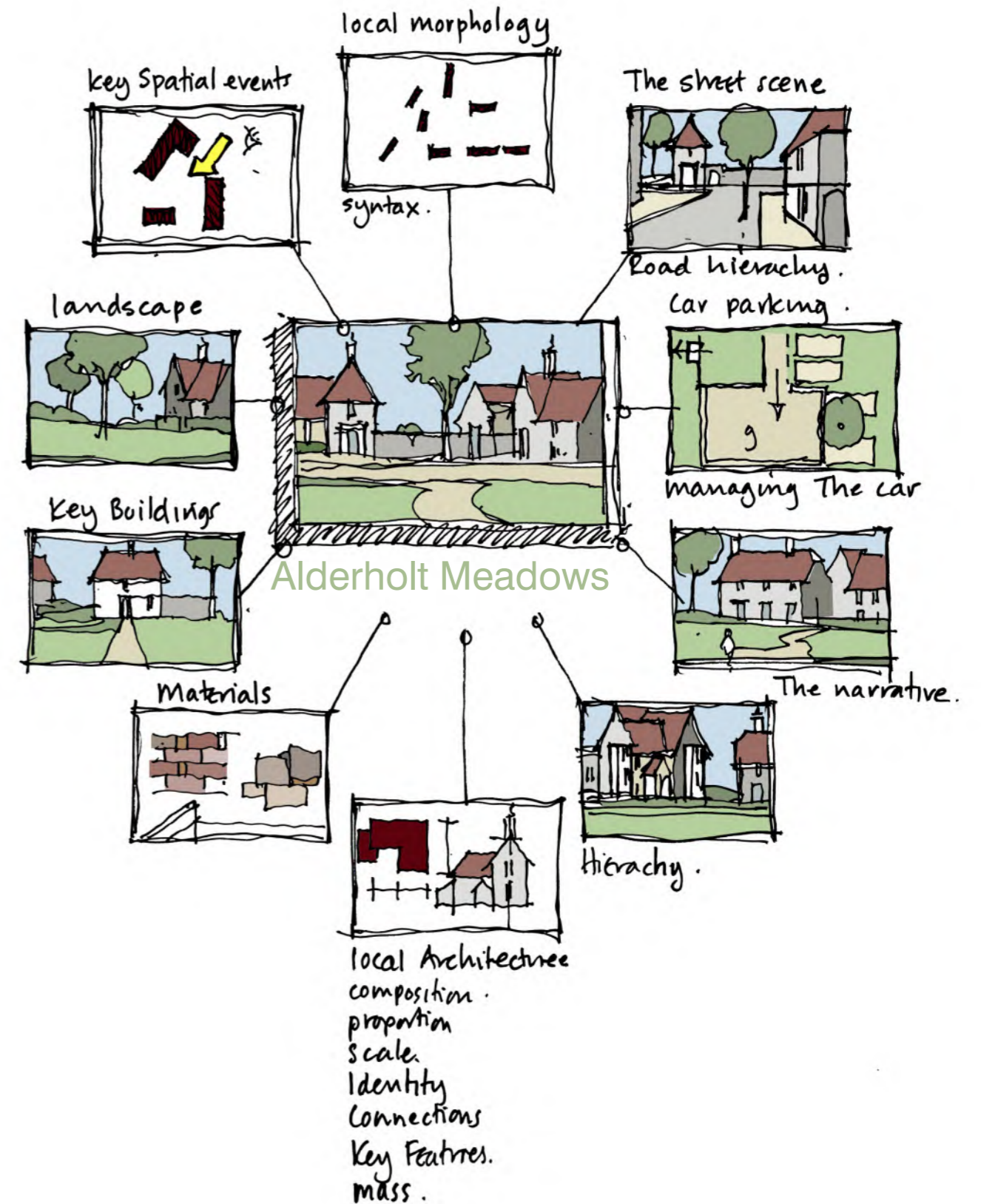

Figure 1

## 1.1. FLOW CHART - DESIGN EVOLUTION

### Alderholt Meadows

- A united desire to create a characterful place that has a locally inspired architecture, sense of arrival, narrative and sense of place that reflects the local Dorset vernacular and that is village like, with its own identity. That this identity shall be created from architecture, spatial settings, materials, and an urban design which is not estate like. That through the creation of a varied place, a community can grow and create a place that feels it is born from its place, not in spite of it and, which can mature and endure.
- Prepare a design code and masterplan to inform how such an intent can be set and with clear design parameters, as a precursor to any detailed reserved matters submission.
- Visit the site, the town, travel the developments so far implemented, visit the wider landscape setting, and assess the context.
- The total design and as each phase is detailed, to offer a clear design intent that is locally inspired from the vernacular and look to the finer historic and local places for design exemplar, example and reference.
- To achieve this, this document seeks to explore local vernacular that can be used successfully to assist in designing, master planning and setting a design code for Alderholt Meadows.
- Define qualitative local environments which can be analysed and used to create a locally inspired DNA toolkit for creating Alderholt Meadows.
- Search district conservation areas, as they represent local environments which have been clearly identified as possessing a character and quality that is worthy and of the local vernacular.
- Identify and analyse.
- Create a locality map showing all district conservation area so that their position and relevance to Alderholt can be understood.
- Select a small quantum for analysis and which offer a variety and extent of experience which can be used as a local reference to identify a vernacular, character of place, anatomy and spatial setting that might be interpreted and imported.



Figure 2 - Indicative masterplan

- Look at Alderholt itself and identify any special characteristics that can also be imported and used as a design tool.
- Analyse each identified area in its spatial setting, morphology, anatomy, architectural narrative, materials, componentry, and character.
- Create a design toolkit from the analysis which can be used as a design generator for Alderholt Meadows.
- Receive our client's brief for the variety, mix and development aspirations.
- Analyse the site and its constraints and opportunities.
- Review all the approved planning data, inherited as a part of the outline consent.
- Travel to the reference areas established from the conservation area identity studies.
- Establish an informed design quality and character benchmark to be used in conjunction with all data to set more informed design parameters.
- Evolve a masterplan.
- Evolve an architectural DNA toolkit (each RMA submission can present its own DNA and vernacular study to support their design submission).
- Develop an accommodation matrix.
- Create house type reference examples.
- Show how these might manifest into an architectural vision that has a synergy with the aspiration and the masterplan.





## 1.2. DESIGN VISION

This Design Code shall form a part of the application documents and should be read in conjunction with all other submitted materials, drawings, and designs. It is anticipated that this Design Code shall inform any subsequent reserved matters application/detail design and, that the details contained herein shall form the basis (but not limited to) how the urban design, morphology, character of place, spatial settings, street character, architectural character, landscape architecture and hardscape shall evolve and be finalised in all entirety and for any future reserved matters/full application for each phase.

This Design Code sets out a vision for the development of the site, together with a number of design principles, which are set out below.

## 1.3. DESIGN CODE PRINCIPLES

- Preserve the strong connection with the local vernacular architecture of Dorset.
- Build in the principles of sustainable development from the outset to create a long-lasting and valued neighbourhood capable of change over time.
- Create parcels of development in a strong landscape framework that provides a network of green infrastructure.
- Create a strong sense of place, character and identity by ensuring development is of the highest quality and ensuring that there is a mix of housing types, developing a balanced neighbourhood.
- Vary the grain across the site, with all set as a series of, creating intimate groups that are travelled and experienced within a narrative, rather than being estate like. All will form a direct connect and design led housing promotion that should join the character of place and the local vernacular. All should unite visually and join the craft and detail evident within the wider setting to create a united design solution.
- Enhance accessibility by all modes for all residents and visitors by establishing a clear and safe network of interlinked roads, lanes, shared surface courtyards, landscaped spaces, pedestrian routes and with access to public and private amenity.
- Preserve existing site characteristics, such as important trees, hedgerows, archaeological features and unite with the retained architectural forms/features on site and their craft.
- Create a variety of open spaces and walking routes to cater for play, dog walking, and to provide a setting for the development.

- Provide sustainable urban drainage measures.
- To create a varied scale, ranging from 2 and 3 ½ storey houses down to 1, 1 ½ storey garages and subservient buildings, with traditionally pitched roofs. A varied scale that has a synergy with the heights and extent of the existing built forms identified from design exemplar, such that a variety in scale will then (through architectural treatment) create a character that possess hierarchy.
- That the urban design will avoid a mundane and repetitious treatment of garage/house designs which are each serviced (estate like and with monotony) from the principle access.
- That the use of mews courts and rear serviced courts that contain parking and residential feature (as with Poundbury) as well as the models explained in MfS 1 & 2, shall be utilised to avoid an over dominance of the car/garage/parking within the character of place and street scene settings, and to avoid the pattern of garage/house – garage/house as a dominant street scene feature.
- That the guidance within CABI/DETR – DB32, Places Streets and Movement and Better Places to Live are still worthy of reference and should be used.
- That the principles and objectives of The National Design Guide – Planning Guidance for Beautiful, Enduring & Successful Places – 2021, forms an integral part of the design led and varied community that is planned.
- That the Dorset SPDs and other LPA guidance will join the collection of material for reference.



### National Design Guide

Planning practice guidance for beautiful, enduring and successful places



Ministry of Housing, Communities & Local Government

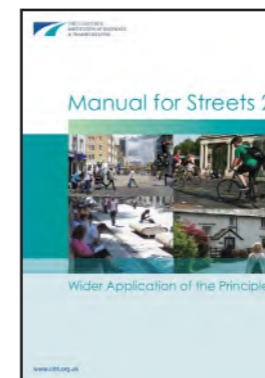

## 1.4. DESIGN TEAM

The team responsible for the preparation of the DAS has been led by the chief Project Architects/Urban Designers:

Scott Worsfold Associates Ltd. and comprises the following core members:

- 

Client / Project Director (Mark Hewett) - Dudsbury Homes (Southern) Ltd

- T: 01202 570471

Investor Contract - WH White Ltd - Nathan Ross

- T: 01202 612504

Planning Consultant - Intelligent Land - Nigel Jacobs

- T: 01202 570471

Landscape Architect - Urban Initiatives Studio - Hugo Nowell

- T: 0203 5670716

Transport - Paul Basham Associates - Tom Peters

- T: 01235 352150

Drainage - Campbell Reith - David Smith & Garry Taylor

- T: 07977 922 150

Arboriculture - Haydens – Nick Hayden

- T: 01722 657423

Ecology - ABR Ecology - Becki Smith

- T: 07918 901212

Ecology - EPR - Rebecca Brookbank

- T: 01962 794731

- Archaeology - Wessex Archaeology - Andy Reid

T: 0172 232 6867

- Sustainability/Energy/Net Zero – Hydrock - Josh Bullard/Pamitta Mall

T: 01179 459225

- Viability - Intelligent Land - Mark Sturman

T: 01202 570471

- Acoustic - Waterman - Mark McLagan

- Air Quality assessor - Waterman - Andrew Fowler

- Ground Conditions - Waterman - Freddie Alcock

T: 02079287888

- Utilities

EWA - Eric Woodgate T: 07775 778193

Hydrock T: 01179 459225

- Lighting - DFL - Daniel Spreadborough

T: 01962 855080

- Technical Delivery - Rapleys - Jason Mound

T: 0370 7776292

- Education Consultant - Alfredson York - John Powell

T: 01491 525200

- Engagement consultant - Devcomms - James Mallinson

T: 01296 678 320



## 1.5. PURPOSE OF THE DESIGN CODE

This Design Code has been prepared to act as a 'living' document to guide the development of Alderholt Meadows and to provide a framework to deliver the design quality and distinctiveness inherent in the masterplan, and the design initiative to create an enduring and characterful place that has a character rooted in the local area and local vernacular.

As such, the Alderholt Meadows Design Code has been prepared as a delivery tool to help implement the Alderholt Meadows masterplan and any subsequent Reserved Matters Applications/Full Applications.

The code sets out the essential elements that must be delivered to implement the masterplan. The elements are set out in a structured way that reflects the scale and significance of each component, with key principles followed by more detailed studies that facilitate the core place making principles.

The code maintains a sense of cohesion across the development, whilst allowing architectural flexibility in detailed proposals which will be developed as each Reserved Matters Application comes forward. Essentially, all should use the local vernacular traditions to generate a locally inspired place, that is united with the historic details in the local and wider vicinity, but at the same time integrating modern modes of living. A generic, anywhere/everywhere total design in its architecture, landscape architecture and urban design is to be avoided.

The code is designed to be updated as the scheme moves forward. The constant review of the principles set out in this document will ensure that design quality will be informed by the development itself and as each phase is conceived, evolved, created, and then tabled.

This code has been prepared as a part of a complete and managed design control toward the final implementation of the finished community. It seeks to apply standards for built features, landscaping, and components, such that the implementation of the scheme and any future design submissions by any alternate landowner/architect/agent has complete synergy with the design intent tabled by this code and that the same is controlled in terms of its visual sensation, character and constructional/design quality.

The design team wishes to encapsulate design quality and set standards for the future development of the site, to ensure that the quality of this new community is founded upon clear and viable design principles whilst allowing flexibility to address advances in technology and construction techniques.

The code is intended to be a mechanism to coordinate the implementation of different elements within the development and provide a framework for the entire site. It will therefore be relevant to all, even if all is subsequently varied or applied in different phases of the development.



## 1.6. MANAGING THE DESIGN PROCESS

The design process has been led by the long-term intention of the applicant to deliver a high-quality residential development.

The design process has sought to translate this broad objective into a scheme that is deliverable, both in terms of achieving the level of quality sought and in quantum. The design process has thus had to be managed to ensure that the broad objectives and design principles set out in the Design Code and inherent in the masterplan can be translated into a finished development.

The project team and our client have created an aspirational scheme, which can be secured through future Reserved Matters Applications (RMA) and turned it into a viable and deliverable entity, which is attractive to developers and, which secures the delivery of the design quality that the scheme aspires to, via the use of this Design Code and the body of all other submitted data.

In this respect, the Design Code represents a key tool in the management of that design process, as it will provide the essential framework through which the design of the scheme will be delivered.

## 1.7. MECHANISMS FOR DELIVERING QUALITY

The Design Code represents the primary mechanism for delivering quality. Future reserved matters applications will be judged against the principles and design criteria set out in this code, together with other relevant development control related matters.

This code has evolved to act as a design guide to sponsor an exemplary design initiative that is born of its place and led by the Dorset vernacular. It is not a tool to fight poor design. Each RMA should evolve within a synergy of the whole and with a holistic design vision. All may be by different designers, architects, practices or agents but all within a commonality of design experience that can and should possess synergy but also subtle variety. Any place is understood and experienced in its richness and by variety, but variety should always sit in harmony, not in conflict or shocking contrast.

Each RMA/detailed design submission should be judged on its own merits and this code does not offer anything more than an arena from which high quality, locally invested and context driven design should manifest which should be judged in its own right as each is tabled before Dorset Council and the Client, who will steward the Design Code.

Through this outline application, the form and qualitative intent of the actual development can be fixed, with the code representing the primary means through which any subsequent design submissions will be prepared and coordinated.

The Design Code is not an overly prescriptive document and does not seek to constrain detailed design decisions regarding the exact appearance of the development. However, it does ensure consistency in respect of the key design fundamentals, such as road structure, general building dimensions, landscape objectives, character areas and key architectural features and materials.

As stated, the code should not be read as a design manual, but as an evolving document that guides and details parameters through which high quality design will be delivered. Design is organic and as such, should other variants of features or treatments of architecture be warranted and which fit within the established local vernacular then, the intent of this code embraces such variety.

## 1.8. PREPARING THE DESIGN CODE

The Design Code has been prepared by SWA with input from the whole design team, in a coordinated and holistic design approach, as instructed by the applicant. It fixes certain design elements, and the detail which is considered important to realise the long term vision and quality intent. The code is structured in a logical format to explain the hierarchy and place making principles which should then inform any future Reserved Matters applications.

## 1.9. STRUCTURE OF THE CODE

The Design Code is set out in ten principle elements, namely:

- Local heritage reference
- Constraints and opportunities
- Regulating plans
- Indicative masterplan
- Streets and movement
- Landscape
- Lighting
- Sustainability
- Utility and energy
- Buildings

These sections of the code have been prepared in a coordinated manner, and include elements relating to architectural features / materials and design character.



*Illustrative 3D watercolour image subject to detail design - Formal street to park*

### 1.10. DESIGN CODE VISION

The vision is to achieve desirable and attractively designed family homes, open spaces that respond to how residents wish to use them, amenity spaces that respond to the existing attractive features of the site and its surroundings, and an overall living environment that engenders and supports a true community.

### 1.11. DELIVERING THE PROJECT

Delivery of the scheme will be the responsibility of many persons and organisations, many of which are not yet involved in the process itself. In this regard, the Design Code represents a key document in ensuring that the vision outlined above, and the masterplan are readily understood and can be translated into an appropriate form of development.

It could be the case that the current design team will remain as a constant through the development, which will ensure a degree of consistency. However, delivering the project itself relies upon many others outside of the team to ensure that the vision is achieved.

### 1.12. FLEXIBILITY

The Design Code should not be viewed as containing absolute design guidelines. It represents the basis upon which we wish to see the development moves forward and should be adhered to in general terms.

The design guidance should be applied flexibly and allow for innovation and positive change, which will assist in delivering the vision. Essentially, the guidelines should be used as a tool for the creation of a high-quality development and not a constraint. The materials and details herein are a minimum design benchmark and not a maximum. They are not a set of design guides setting the minimum common denominator, but a standard which should at least be met or exceeded. It is hoped that this document will be set out in a manner that does not require much change as the development itself moves forward. However, it would be naive to assume that opportunities to accommodate new ideas, concepts or materials will not occur. As such, the integration of flexibility within the Design Code is a deliberate and desirable feature that will assist in meeting the vision.

### 1.13. OVERALL CHARACTER STRATEGY AND DESCRIPTION

This Design Code has been prepared, as part of the Outline Submission, to ensure a sustainable neighbourhood will be delivered to the highest standards of architectural quality, integrity, and coherence.

The Design Code recognises the importance of delivering development that respects the different context around the edge of the site, creating SANG, POS, opportunities for facility, community, leisure, and employment.

All should, in all its place making, urban design, landscape design, architecture and use of materials, express a narrative, variety and sense of place that is rooted in its setting and the local vernacular but which takes the opportunity for creating its own identity as well.

The site is broken down into neighbourhoods / identity areas, to ensure the creation of an exemplar scheme which positively responds to the local vernacular and sensitively addresses the needs of a community which is far reaching and beyond the home.

The design code sets parameters of design, building heights, layout, key visions, methods of context sampling and analysis, form, composition and expressions of mass, boundary enclosures, materials, and density across the character areas to define their identity, relate to their context and the places they can become.

These will form the foundations to allow future RMA submissions and control by the LPA to ensure that quality forms the golden thread through every aspect of "Alderholt Meadows".



*Watercolour view of the development*



*Watercolour view of the development*

SECTION 2 – LOCAL HERITAGE REFERENCE – AREA ANALYSIS

2.1. VERNACULAR HOUSING CHARACTER

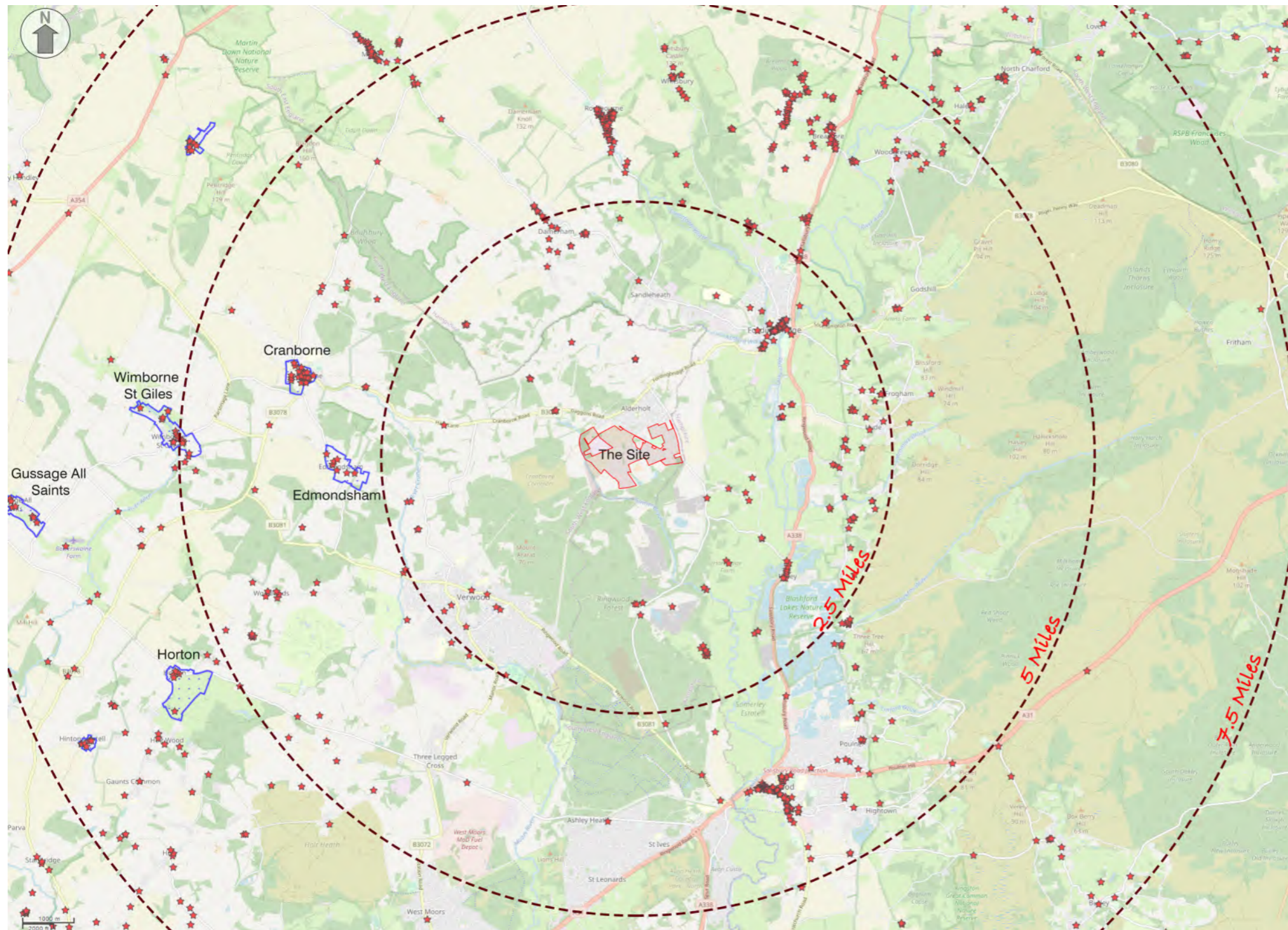

We have carried out an analysis of local conservation areas and selected five areas located in the vicinity of Alderholt. A more detailed analysis of these five areas has been prepared to extract the essence of their character. The identified areas for analysis are:

1. Cranborne
2. Edmondsham
3. Gussage All Saints
4. Horton
5. Wimborne St Giles

- Key:
- The Site
  - ★ Listed Building
  - Conservation Area
  - - - 2.5 - 7.5 Mile Radius

Map identifying conservation areas within a 7.5 miles radius



## 2.2. CONSERVATION AREA APPRAISALS

### Anatomy of Place

The historic environments analysed have grown over time and each represents a built form that is born of place and from local tradition and need. Each could be described as a true tradition and the subject of growth and development, and whose resultant character has reached a point where its character, display of craft, landscape, architecture, setting and narrative, is of a quality which needs to be protected and enhanced. Each was chosen as it represents a subtly different form from another.

From each area study, detail layouts will be created for each RMA that have complete synergy with each key area and in:

- Format
- Roadside condition
- Punctuation
- Views and vistas
- Hierarchy and scale
- Key buildings
- Expression of form
- Morphology
- Landscape

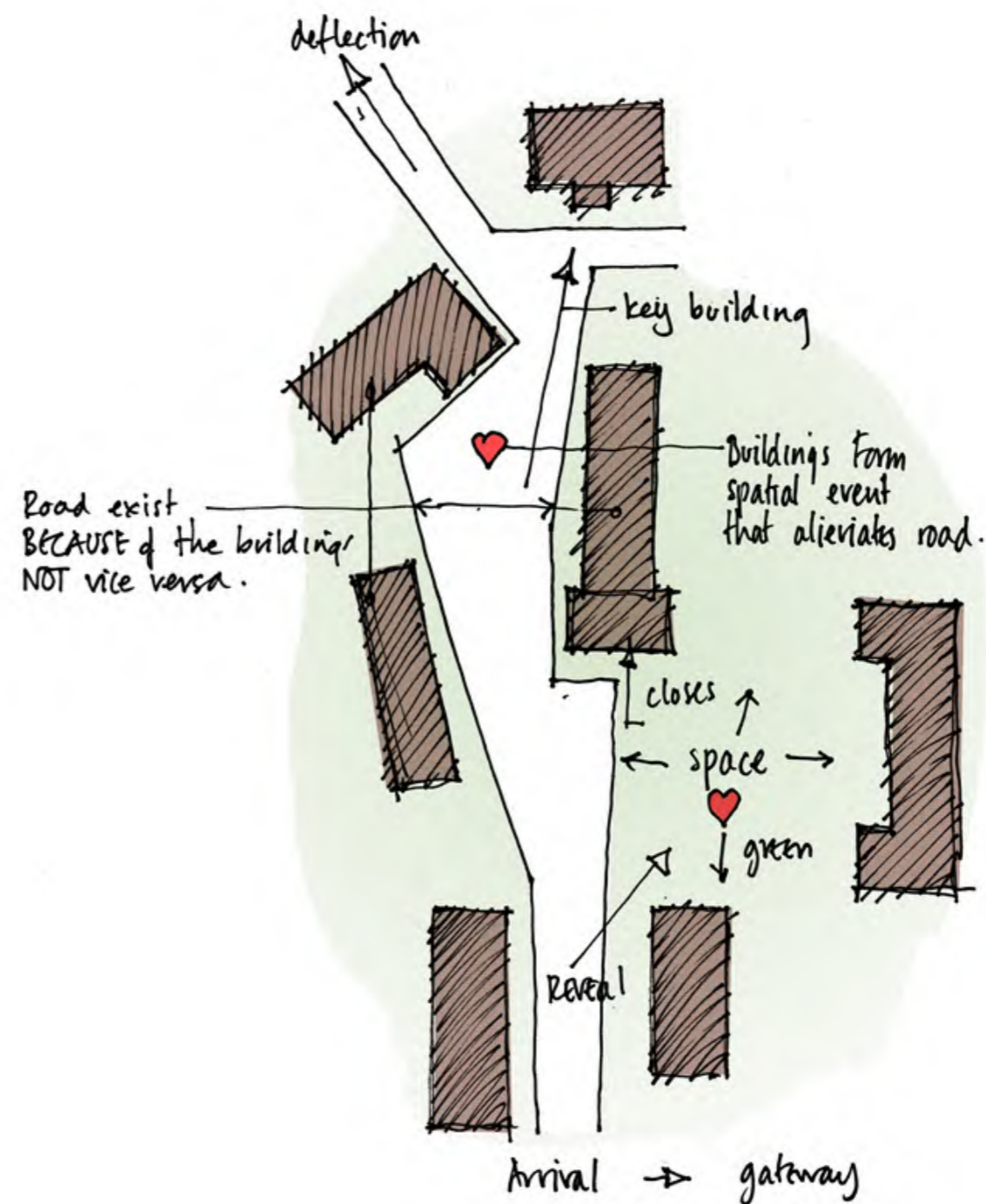

### 2.2.1. CRANBORNE VILLAGE

Cranborne is a village in East Dorset, England. It lies in the valley of the River Crane at the heart of ancient woodland chase.

The village dates from Saxon times and was recorded in the Domesday Book of 1086 as Cranborne, meaning stream (bourne) of cranes.

There are buildings of national importance located in Cranborne:

The Manor House is historically one of the most important domestic buildings in England, incorporating the main walls of a fortified hunting lodge built by King John in 1207–8.

St Mary & St Bartholomew Church is a Grade I listed building. This Norman church was rebuilt around 1252 in Early English style. It holds 14th century wall paintings and a 15th century pulpit.



*Cranborne Manor*



*Painting of fresco, Cranborne Church*



*Cranborne Church*

## 2.2.2. CRANBORNE CONSERVATION AREA ANALYSIS



<b>Spatial layout:</b>	Nucleated form centred on the Square
<b>Typologies:</b>	Compact with coarse sections towards conservation area boundaries
<b>Buildings / House Types:</b>	Mostly residential, houses and cottages, village pub, post office
<b>Landmark buildings:</b>	Cranborne Manor, Red Lion House, No.5 Crane Street
<b>Streetscape:</b>	Prominent boundary walls typically constructed of brick or constructed of rubble or cob and rubble, flint and rubble, stone copings etc, brick walls with tile copings, wide grassy verges, private gardens, mature trees and hedges – historic treescape
<b>Land use:</b>	Mostly residential
<b>Views:</b>	On the village approach, winding lanes conceal views. Within the village landmark buildings and landmark trees act as focal points to close views (example: Crane Street)

*Morphological study of Cranborne. Red line denotes Conservation Area boundary*

2.2.3. CRANBORNE SPATIAL EVENT

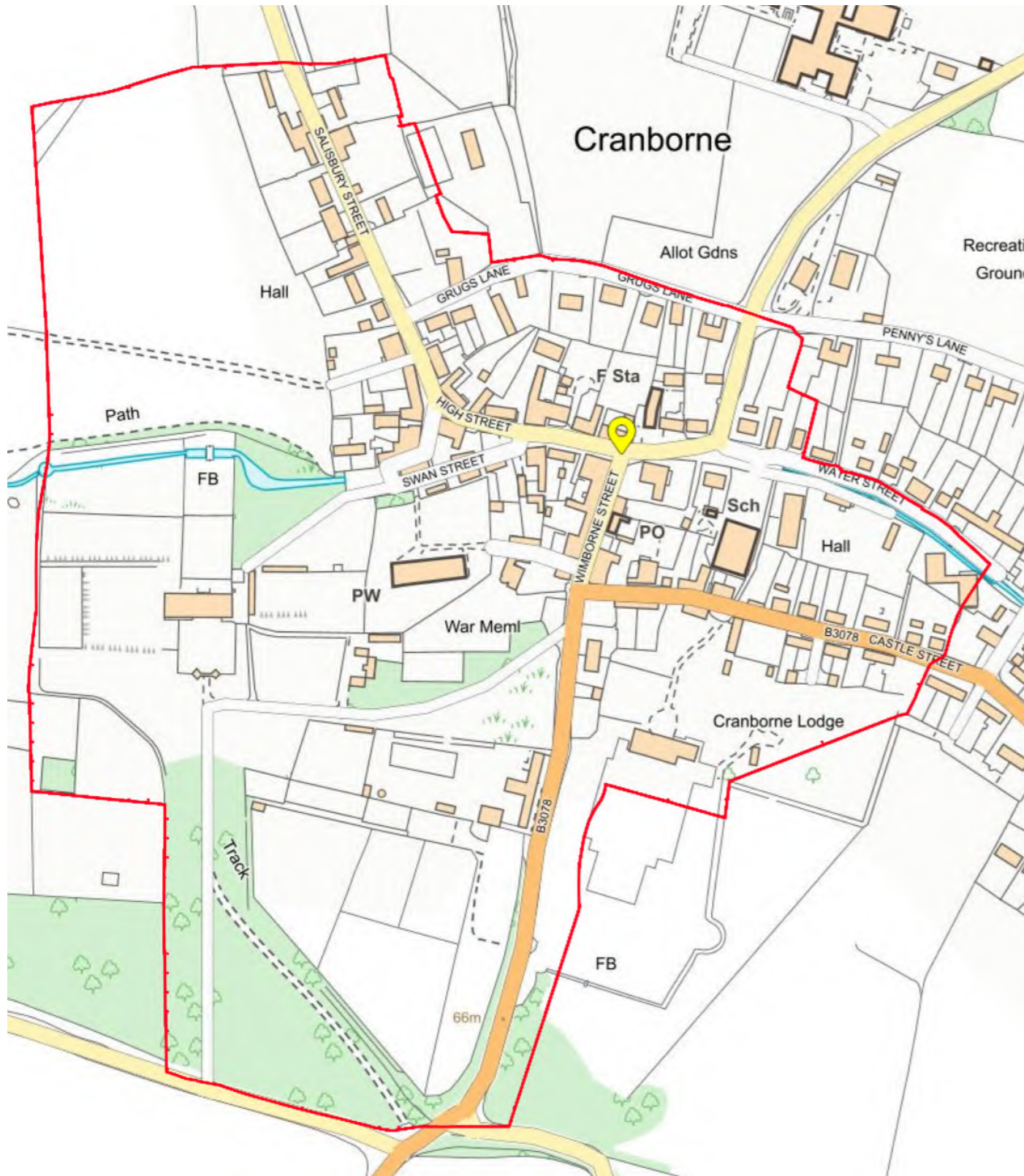

Map of Cranborne showing Spatial Events and Gateways



Street View 1, Salisbury St.



Street View 2, Salisbury St.



Street View 3, High Street



Street View 4, High Street



Street View 5, Wimborne St.



Street View 6, Castle St.



Street View 7, Water St.



Street View 8, Water St.

2.2.4. CRANBORNE KEY BUILDINGS



Map of Cranborne showing Spatial Events and Gateways

● Key Buildings

2.2.5. CRANBORNE KEY DESIGN ELEMENTS

- **Walls:** brick, painted brick, render
- **Roofs:** mostly pitched with clay tile, peg tile, welsh slate, occasional thatched roof
- **Chimneys:** Red brick chimneys
- **Windows:** A mixture of timber sash and casement windows
- **Form:** Mostly traditional form, 2 storey buildings with pitched roofs



### 2.2.6. EDMONDSHAM VILLAGE

Edmondsham (Medesham) is a village in East Dorset. It is situated 2 miles Northwest of Verwood and 10 miles north of Bournemouth.

It is recorded in Domesday and it is likely that more than one of the farms dispersed in the Edmondsham parish were in existence by 1086 since Domesday has three distinct entries. The landmark buildings of the village include The Manor House; a picturesque Tudor manor with Georgian additions standing in over 6 acres of gardens.

Within the Edmondsham House grounds stands the Church of St Nicholas, which dates to the 12th century, but was almost entirely rebuilt in the Victorian period. The main features of historic interest are the grave slabs of the Hussey and Fry families, which have been placed upright around the walls.



*Edmondsham Church*



*Edmondsham House*



*Edmondsham House*

2.2.7. EDMONDSHAM CONSERVATION AREA ANALYSIS

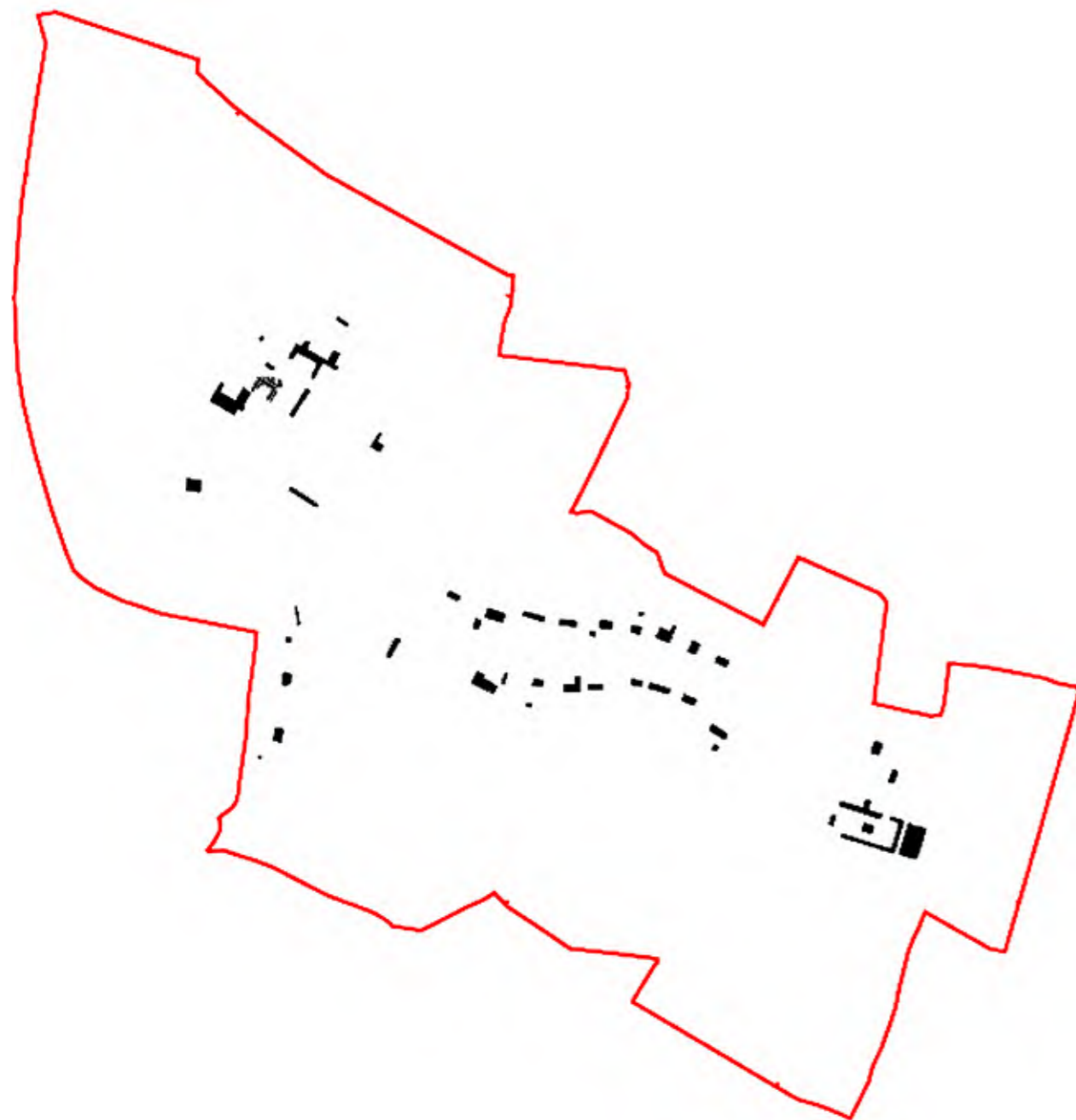

<b>Spatial layout:</b>	Small linear settlement, estate village
<b>Typologies:</b>	Coarse grain, wide fronted buildings located parallel to the road
<b>Buildings / House Types:</b>	Residential
<b>Landmark buildings:</b>	Edmondsham House, Church of St. Nicholas, former Rectory
<b>Streetscape:</b>	Hedging forms predominant boundary treatment, no pavements or kerbs, informal road junctions, wide grassy verges, private gardens, mature trees and hedges – historic treescape
<b>Land use:</b>	Mostly residential
<b>Views:</b>	On the village approach, winding lanes conceal views, village surrounded by woods and copses. Within the village views are closed by the road's curve and mature planting, buildings (Edmondsham's House Gate Lodge), historic pumping station, houses

*Morphological study of Edmondsham. Red line denotes Conservation Area boundary*



2.2.8. EDMONDSHAM SPATIAL EVENT

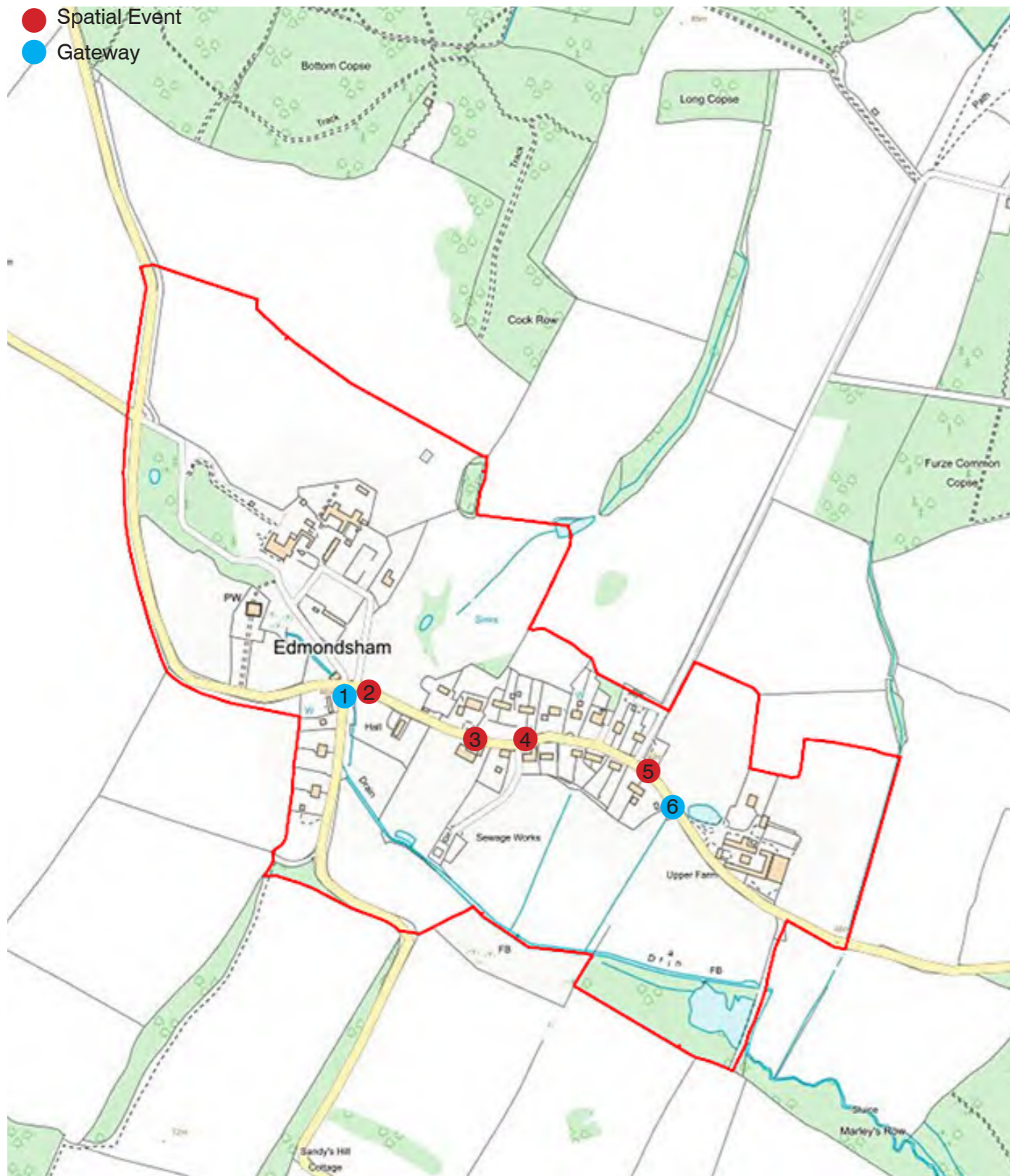

Street View 1, Edmondsham gateway building



Street View 2, Edmondsham gateway



Street View 3



Street View 4



Street View 5



Street View 6



Aerial photo of Edmondsham showing Spatial Events and Gateways

Map of Edmondsham showing Spatial Events and Gateways

2.2.9. EDMONDSHAM KEY BUILDINGS

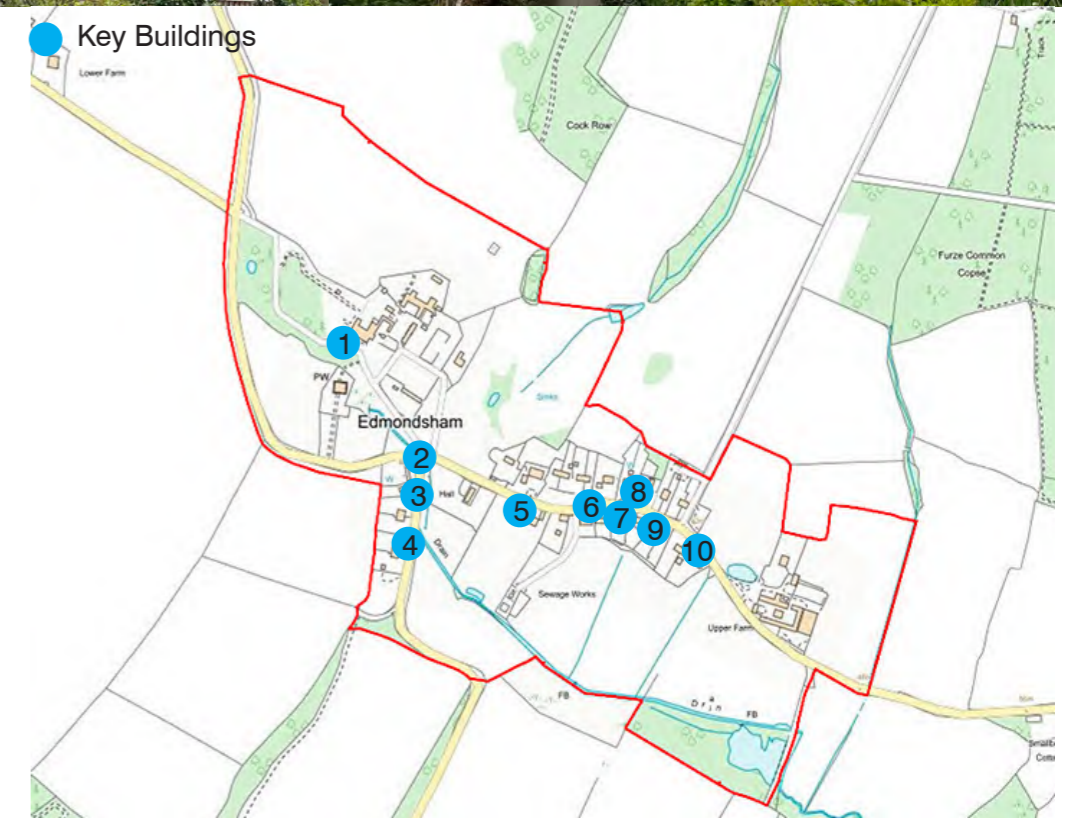

Map of Edmondsham

## 2.2.10. EDMONDSHAM KEY DESIGN ELEMENTS

- **Walls:** red brick, render
- **Roofs:** pitched with clay tile
- **Chimneys:** mostly red brick chimneys
- **Windows:** timber casement windows and sash windows
- **Form:** traditional form 2 storey buildings with pitched roofs



### 2.2.11. GUSSAGE ALL SAINTS VILLAGE

Gussage All Saints is a village in East Dorset situated in an Area of Outstanding Natural Beauty in a vale on Cranborne Chase. Steep valley sides conceal the village from the wider landscape.

Hedgerows and planting demarcate the edges of the village and define its boundaries.

Gussage All Saints Conservation Area includes six listed buildings and several other buildings of historic/local importance.

One of the most significant buildings in the village is the Church of All Saints, a Grade I Listed building. It stands on an elevated ground and the church tower forms a prominent feature in the landscape.

Parts of the church date back to the 14th century. It has been restored and re-roofed in 1864.



2.2.12. GUSSAGE ALL SAINTS CONSERVATION AREA ANALYSIS



<b>Spatial layout:</b>	Linear settlement
<b>Typologies:</b>	Relatively dense build-up, most buildings located parallel to the road, however in the historic village core there are a few cottages characteristically located at a right angle to the road.
<b>Buildings / House Types:</b>	Residential
<b>Landmark buildings:</b>	Gussage House, Former Rectory, Manor Farm, Church of All Saints, Elm Tree Cottage
<b>Streetscape:</b>	Hedging and planting reinforcing the sylvan setting, no pavements or kerbs, informal road junctions, wide grassy verges, private gardens, architectural details feature period gates, original windows and doors as well as townscape elements like the fingerpost and telephone box. Brick boundary walls.
<b>Land use:</b>	Mostly residential
<b>Views:</b>	Village hidden in a valley, concealed from wider landscape. Views from the village are largely obscured by trees and copses.

*Morphological study of Gussage All Saints. Red line denotes Conservation Area boundary.*

2.2.13. GUSSAGE ALL SAINTS SPATIAL EVENT



Map of Gussage All Saints. Red line denotes Conservation Area boundary.



Street View 1



Street View 2



Street View 3



Street View 4



Street View 5



Street View 6



Aerial photo of Gussage All Saints showing spatial events and gateways

2.2.14. GUSSAGE ALL SAINTS KEY BUILDINGS

● Key Buildings



Map of Gussage All Saints. Red line denotes Conservation Area boundary.

2.2.15. GUSSAGE ALL SAINTS VERNACULAR ARCHITECTURE



Photos of vernacular architecture



## 2.2.16. GUSSAGE ALL SAINTS KEY DESIGN ELEMENTS

- **Walls:** brick, painted brick, render, one example of a framed structure
- **Roofs:** pitched with clay tile, thatch
- **Chimneys:** Mostly red brick chimneys
- **Windows:** Timber casement windows & sash windows
- **Form:** Traditional form 2 storey buildings with pitched roofs



### 2.2.17. HORTON VILLAGE

Horton is a small village 6 miles north-east of Wimborne and 5 miles west of Cranborne. It is surrounded by open land and enclosed by higher ground on all sides.

Horton was originally a monastic centre. Its Priory, founded in 961, was dedicated to St. Wolfrida, an abbess who died in the settlement. Both the present Church and Abbey House stand on the site of the monastery, erasing all traces of the original building.

The Conservation Area of Horton was designated in November 1989 and its boundaries enclose almost the entire village.

One of the village's landmarks is Horton Tower: a folly built in 1726. It is constructed from red bricks, beautifully detailed and can be seen for miles around.



2.2.18. HORTON CONSERVATION AREA ANALYSIS

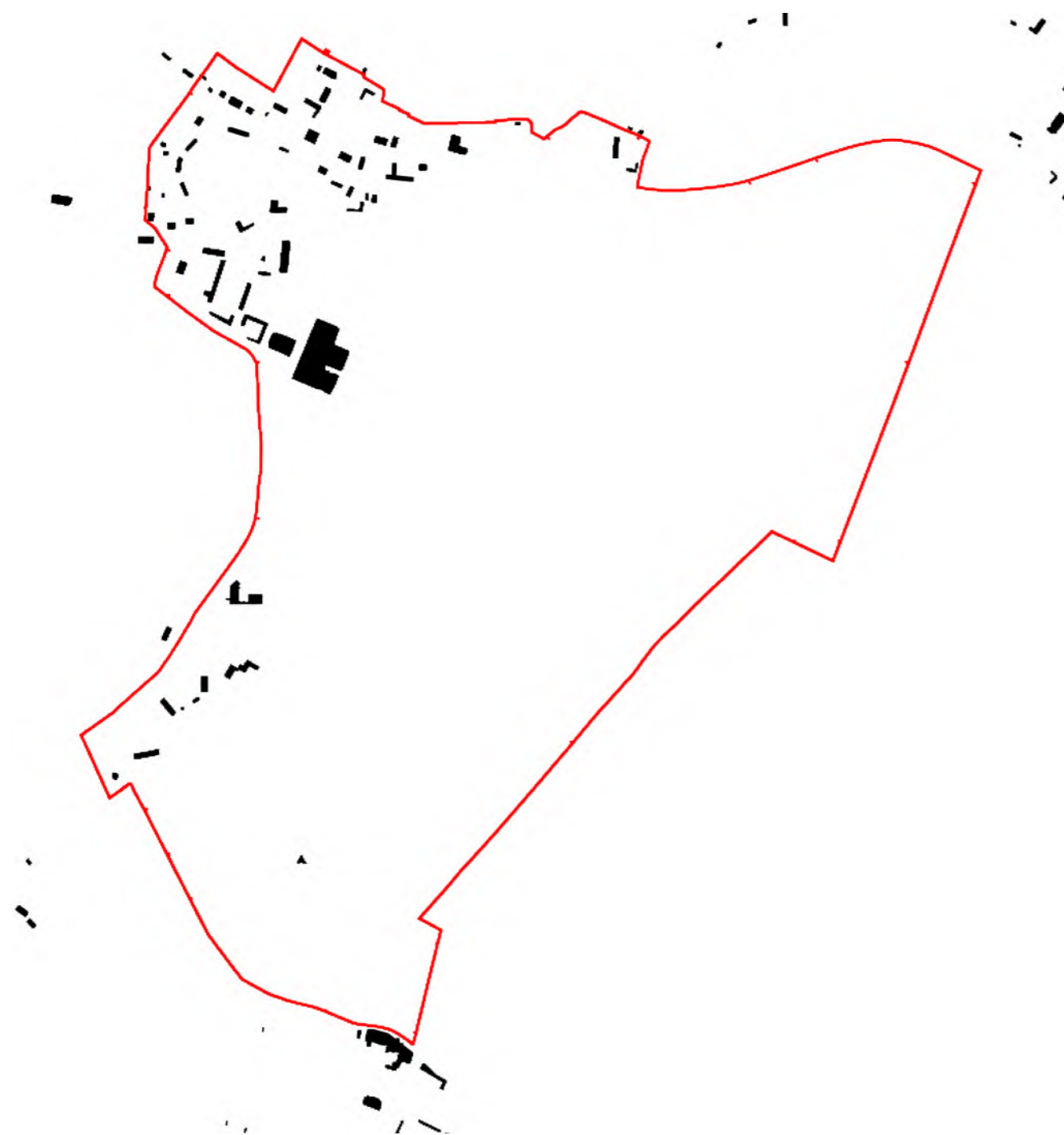

<b>Spatial layout:</b>	Linear settlement
<b>Typologies:</b>	Relatively dense build-up, older buildings in the village concentrated together and joined up by brick boundary walls
<b>Buildings / House Types:</b>	Residential and agricultural
<b>Landmark buildings:</b>	Church of St Wolfrida, Abbey House, Barns at Manor Farm, Horton Cottage, Orchard Farm, Horton Tower, village pump
<b>Streetscape:</b>	Hedging and planting reinforcing the sylvan setting, no pavements or kerbs, informal road junctions, wide grassy verges, private gardens, brick boundary walls
<b>Land use:</b>	Residential and agricultural / farmland
<b>Views:</b>	Rolling down hills surrounding the village, the village itself compact and enclosed

*Morphological study of Horton. Red line denotes Conservation Area boundary.*

2.2.19. HORTON SPATIAL EVENT

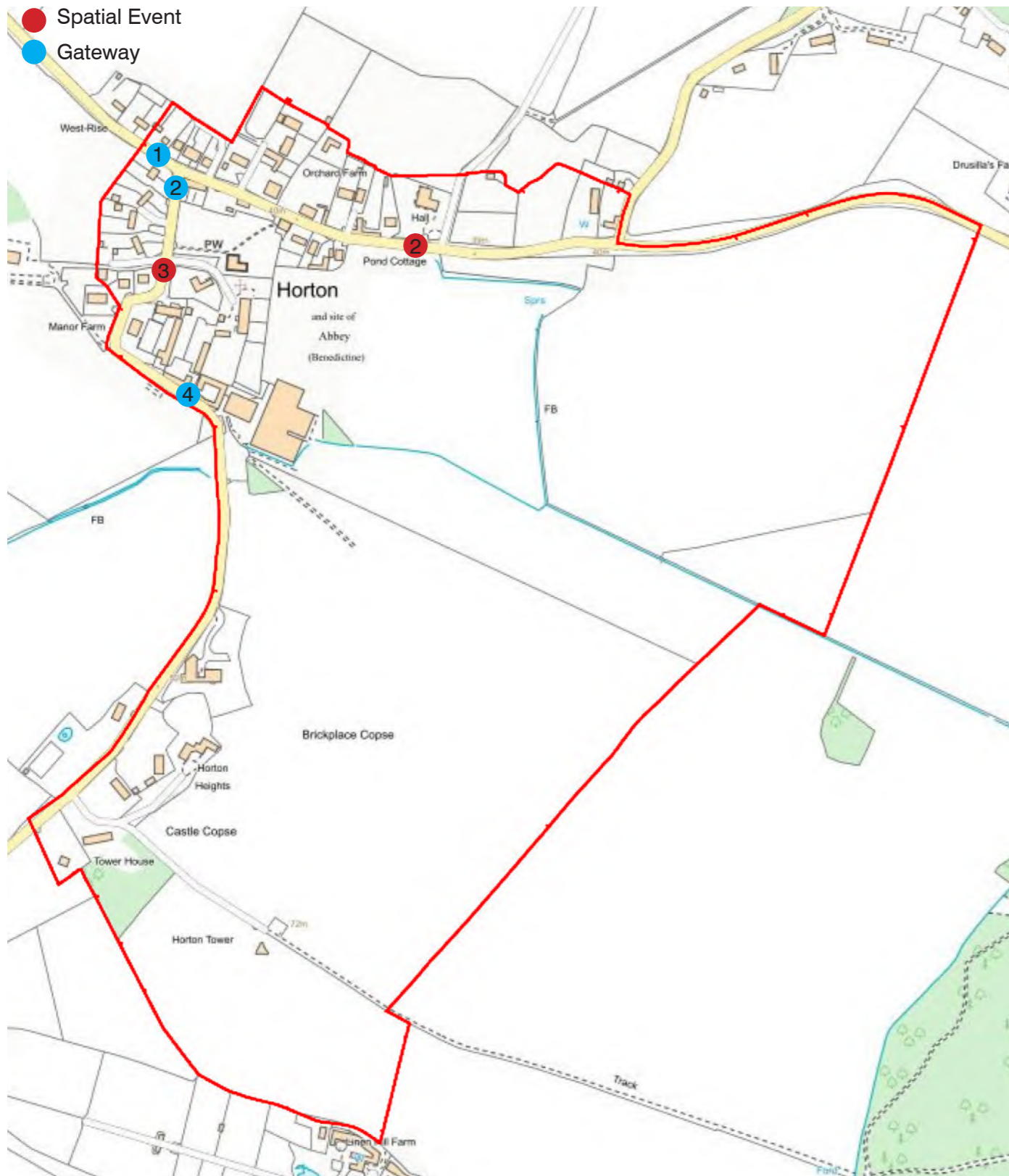

Map of Horton showing spatial events and gateways. Red line denotes Conservation Area boundary.



Street View 1



Street View 2



Street View 3



Street View 4



Aerial photo of Horton showing spatial events and gateways

2.2.20. HORTON KEY BUILDINGS

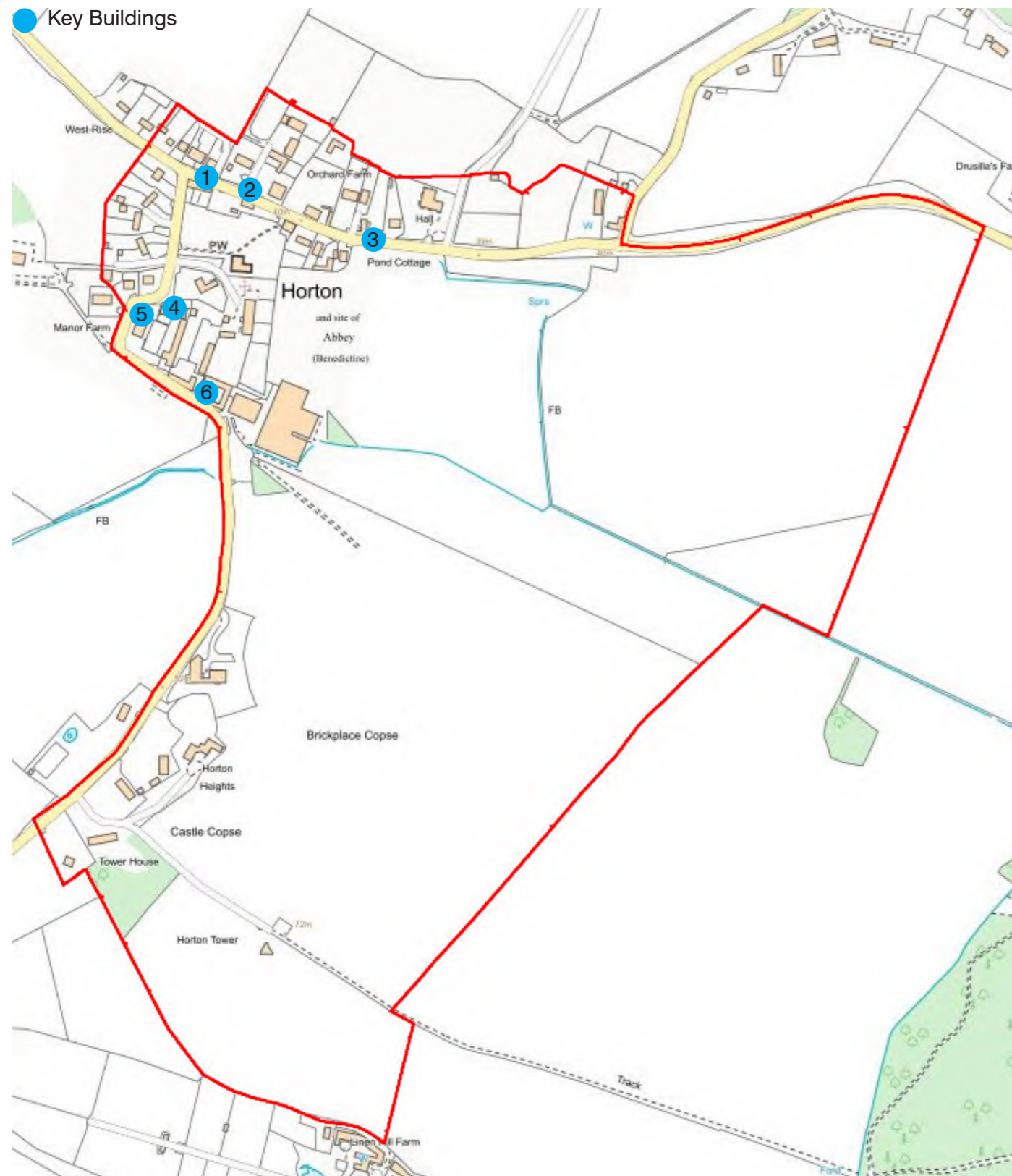

Map of Horton. Red line denotes Conservation Area boundary.

## 2.2.21. HORTON KEY DESIGN ELEMENTS

- **Walls:** brick, painted brick, render, roughcast (Horton Cottage)
- **Roofs:** pitched with clay tile, thatch, slate (row of Victorian cottages)
- **Chimneys:** Mostly red brick chimneys
- **Windows:** Timber casement windows
- **Form:** Traditional form 2 storey buildings with pitched roofs, agricultural buildings / barns



### 2.2.22. WIMBORNE ST GILES VILLAGE

Wimborne St Giles is a small, picturesque village in East Dorset.

The 'village of St Giles' was recorded in the Domesday Book of 1086 and therefore it can be assumed that its origins go back much further into Saxon times.

The village is largely agricultural, with residents generally commuting to nearby cities and towns for employment.

There are many buildings of historic importance within the village, one of them being the Parish Church.

Although the church has medieval origins, its first rector being recorded in 1207, the present building has an 18th century core with late 19th and early 20th century additions.



2.2.23. WIMBORNE ST GILES CONSERVATION AREA ANALYSIS

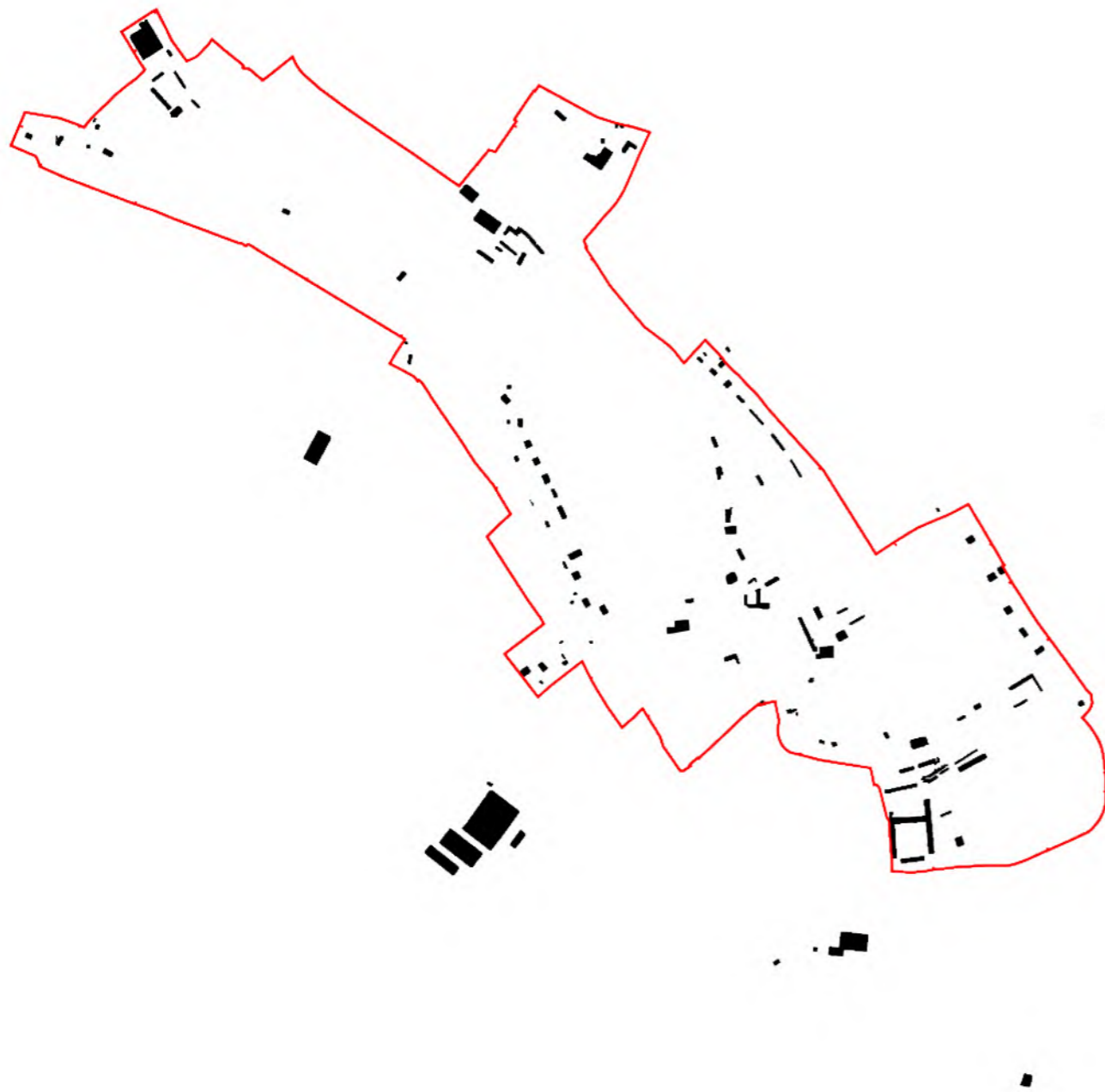

<b>Spatial layout:</b>	Linear settlement in the shallow valley of River Allen, coarse build-up
<b>Typologies:</b>	Manorial Estate (house and the grounds)
<b>Buildings / House Types:</b>	Residential, church, school, shop, village hall, public house, post office
<b>Landmark buildings:</b>	St Giles Church, Alumshouse, Rectory, Mill House, thatched cottages
<b>Streetscape:</b>	Continuous hedging, meandering alignment of the road, no paving, open green spaces, presence of the river, bridges
<b>Land use:</b>	Residential and agricultural / farmland
<b>Views:</b>	Open green spaces / farmland, winding lanes

*Morphological study of Wimborne St Giles. Red line denotes Conservation Area boundary.*





2.2.25. WIMBORNE ST GILES KEY BUILDINGS



Street View 1



Street View 2



Street View 3



● Key Buildings

Map of Wimborne St Giles. Red line denotes Conservation Area boundary.



Street View 4



Street View 5



Street View 6



Street View 7

2.2.26. WIMBORNE ST GILES VERNACULAR ARCHITECTURE



Photos of vernacular architecture

## 2.2.27. WIMBORNE ST GILES KEY DESIGN ELEMENTS

- **Walls:** brick, timber-framed, brick parapet gables, render (Bull Public House), flint present in boundary walls
- **Roofs:** pitched with clay tile, thatch, slate
- **Chimneys:** Decorative brick chimneys
- **Windows:** Timber casement windows, leaded glass
- **Form:** Traditional form 2 storey buildings with pitched roofs, agricultural buildings / barns



### 2.2.28. ALDERHOLT

The first use of Alderholt as a name is found in Edward II's reign when a manor was created and called Alderholt Meadows on Cranbourne Chase. Alderholt was the most eastern part of the parish of Cranborne (Dorset), which at the time was the largest parish in England.

Alderholt has expanded to the south of the main road since the mid 20th century to contain the several hamlets that originally existed along this section of the main B3078 road, which connects Alderholt to Fordingbridge and Shaftesbury.

Originally the village was served by the railway station named Daggons Road, situated to the west of the village by the pub – The Churchill Arms. Today, Alderholt typifies a car reliant development of the late 20th century, consisting of the predominantly 1 and 2 storey dwellings in a suburban setting. Today the village has a population of 3,171.



2.2.29. ALDERHOLT ANALYSIS



<b>Spatial layout:</b>	Linear village with arterial routes terminating in cul-de-sacs
<b>Typologies:</b>	Regular medium grain associated with late 20th century development
<b>Buildings / House types:</b>	Residential: 2 storey cottages and houses Village pub / local shop services
<b>Landmark buildings:</b>	Churchill Arms, Alderholt Chapel
<b>Streetscape:</b>	Suburban with CBF boundary walls, grassy verges, private gardens, mature trees and hedges
<b>Land use:</b>	Mostly residential
<b>Views:</b>	Narrowing views at Weak Gateway moments when arriving from either east or west.
<b>Local focal points:</b>	Co-op convenience store, Alderholt Chapel, St James CE First School

*Morphological study of Alderholt.*

2.2.30. ALDERHOLT VERNACULAR ARCHITECTURE



Photos of vernacular architecture

SECTION 3 - CONSTRAINTS AND OPPORTUNITIES

Content of the DAS is an essential part of the design evolution that has fed into this code. Whilst the code duplicates certain aspects for ease of reference, the DAS in its entirety completely informs contents of this appendix.

The site has a number of constraints and opportunities. A constraint is simply an existing condition which should be acknowledged and considered in a design response. In recognising that such constraints exist and in factoring in their condition and relation to the creation of place, they present an opportunity. This opportunity is directly related to their condition and retention, such that they become a part of the masterplan and place creation. Such constraints are all identified layer by layer on the subsequent diagrams and then finally in a combined diagram which absorbs all constraints into a whole. This is then used to inform the indicative masterplan.

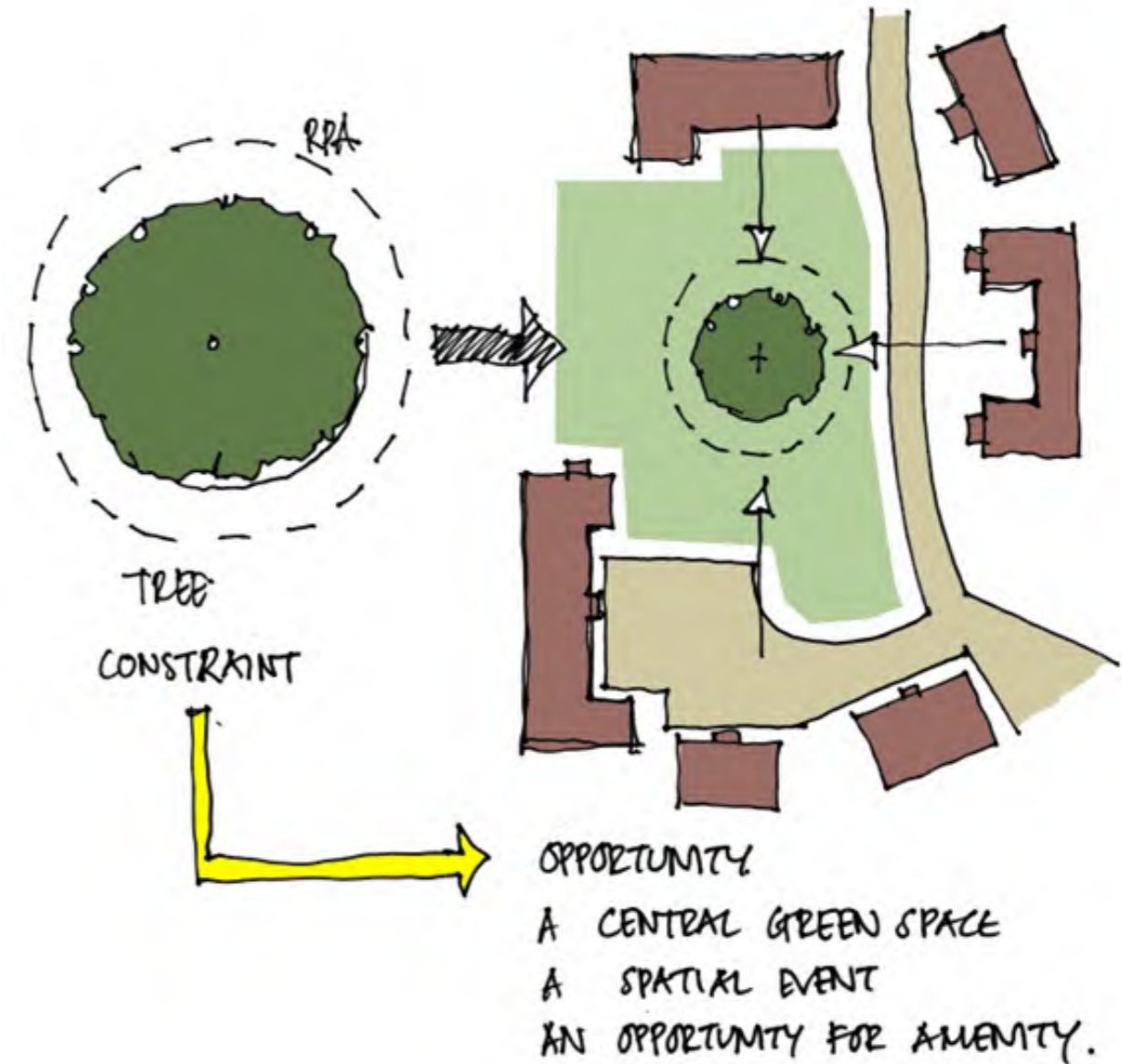

Worked Example



3.1. CONSTRAINTS AND OPPORTUNITIES – INFRASTRUCTURE

CONSIDERING:

- INFRASTRUCTURE
- ACCESS
- PEDESTRIAN AND CYCLE PERMEABILITY
- SERVICES

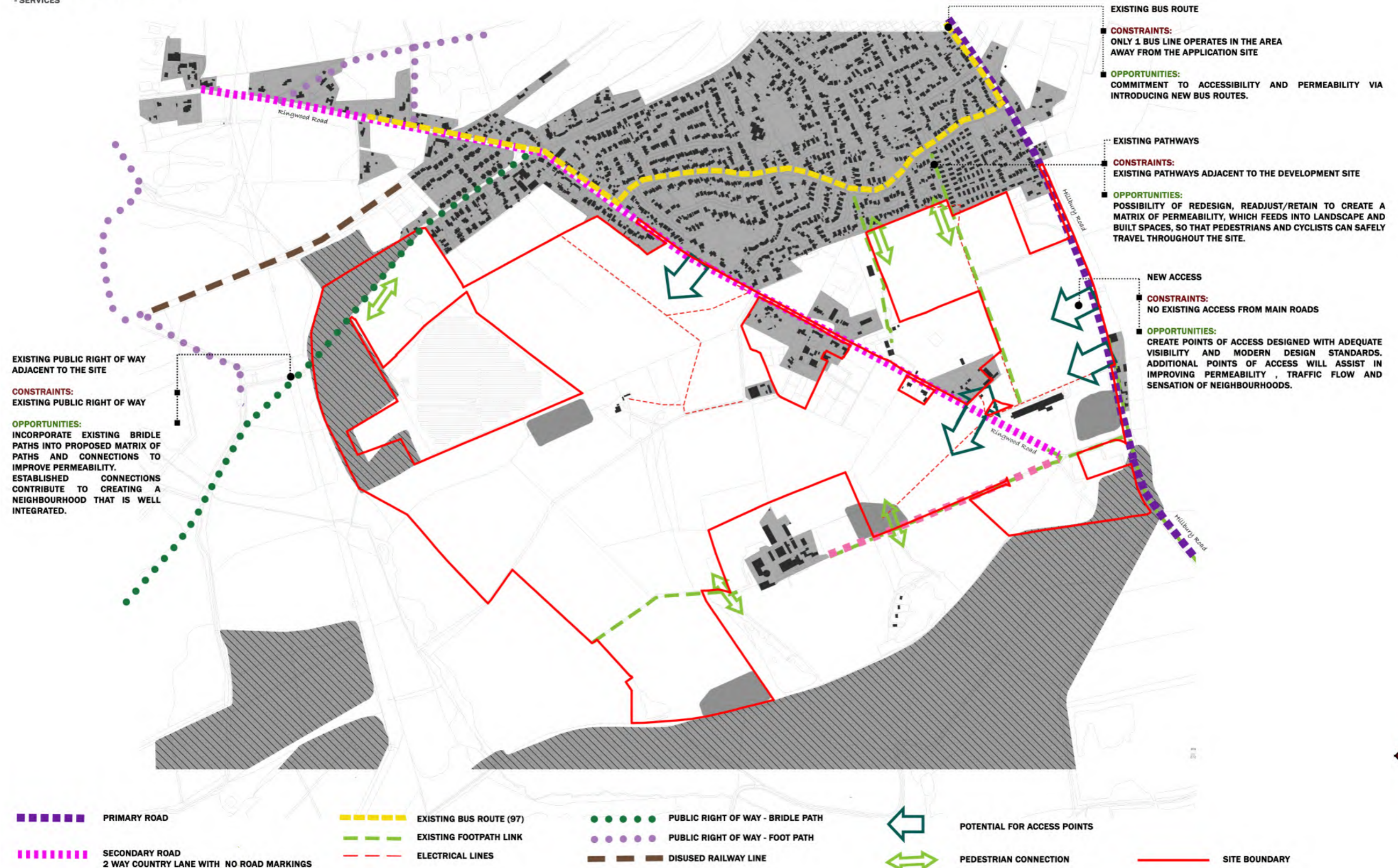

3.2. CONSTRAINTS AND OPPORTUNITIES – LANDSCAPE AND ECOLOGY

CONSIDERING:

- TREESCAPE
- HABITAT
- LANDSCAPE CHARACTER
- EXISTING WATER RESERVOIRS AND FLOOD ZONES



3.3. OVERALL CONSTRAINTS AND OPPORTUNITIES ANALYSIS

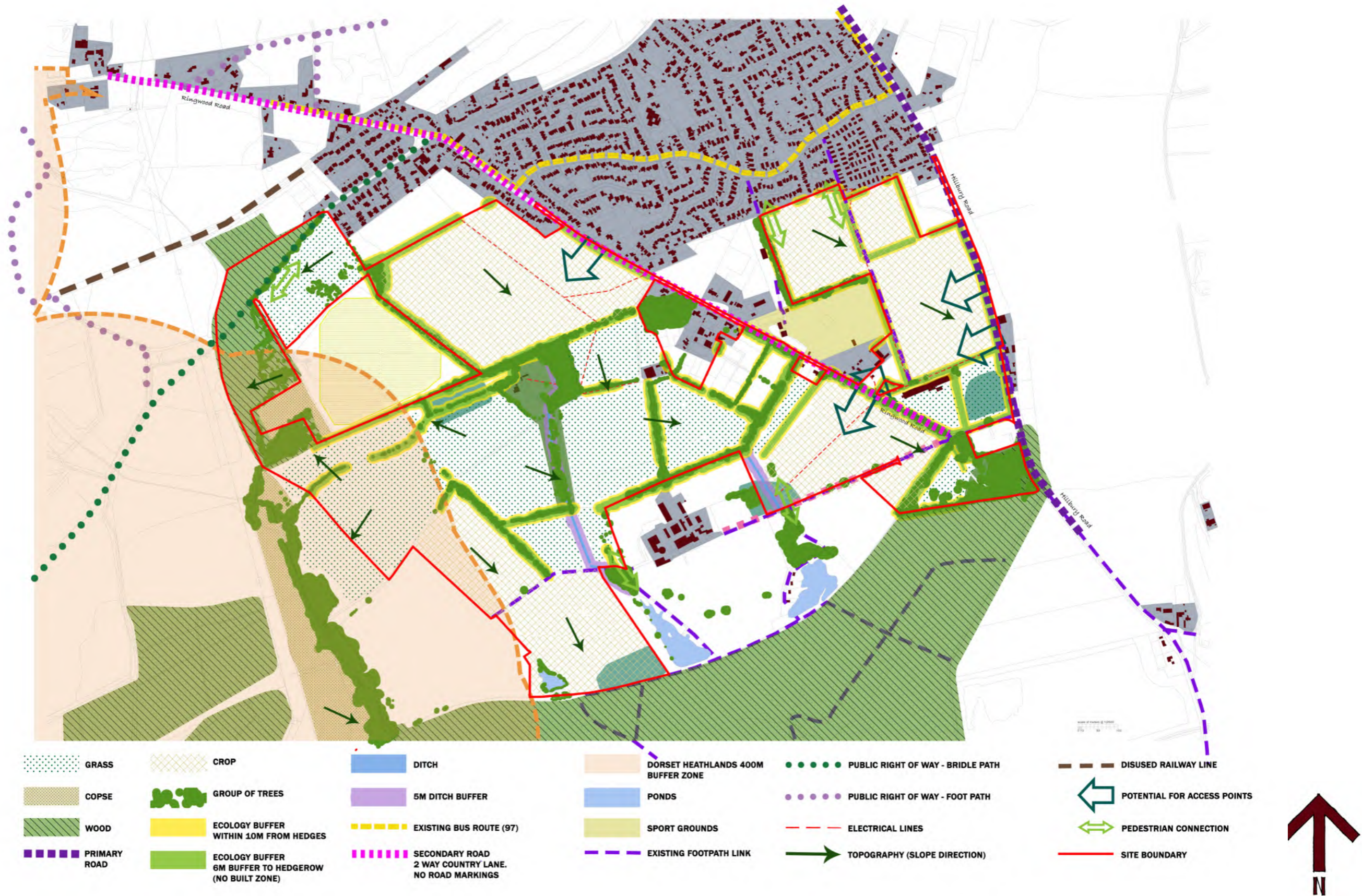

## SECTION 4 – INDICATIVE MASTERPLAN

### 4.1. THE MASTERPLAN

The masterplan has been detailed to respond to the vision for the Alderholt Meadows. This section details its genesis, identifies its key features, and defines the principles that will form the backbone of the development of the site.

#### 4.1.1. GENESIS

A masterplan has been prepared as a forerunner to a future and more detailed design layout, to be prepared for each Reserved Matters Planning Application. This masterplan is an evolved design solution that recognises the site's context and a response to the constraints and opportunities offered by the site.

The submitted masterplan has evolved and culminates in a final design that responds to the parameters and the opportunity to enhance the site whilst respecting the basis of the outline consent AND as a reflect of the Dorset vernacular, the typical morphology and spatial settings that they contain.

#### 4.1.2. FINALISING THE MASTERPLAN

The masterplan identifies the key features of the scheme, defines the interface between the development areas and the structural landscaping that is integral to the scheme. It also defines the spaces within which development activity is focused.

It creates an arrangement which is very carefully considered to achieve the required quantum of built form, within a variety of scale and extent which is measured but, also creative.

Its creation is one that has a sense of arrival, character and a sense of place. It has a narrative and can be explored as a journey throughout the interconnecting spaces. How each form sits, its size, footprint, relationship to garden and orientation/aspect have all been applied as a hierarchy and bespoke solution to the site and its constraints and opportunities.

It plans all adequately with parking arranged such that it will not dominate, carefully creating a sense of enclosure and intimacy of architectural form whilst also creating adequate private amenity, space for utility, bins and access.

### 4.2. MASTERPLAN PRINCIPLES

- Principle 1 - Create an attractive, landscape led, environment that draws greenery through the site and connects with existing adjacent features.
- Principle 2 - Provide an internal road network that is suited for its purpose, but which integrates with the open space and dwellings to create a non- dominant highway led format.
- Principle 3 - Retain and enhance substantial elements of the existing landscaping, to import and maintain its character.
- Principle 4 - Ensure that the scale and proportion of new buildings is appropriate to their surroundings and that all is cognitive and legible.
- Principle 5 - Provide a mix of housing types to support families and to recognise the location of the site.
- Principle 6 - Create clearly defined routes within and through the site for pedestrians and cyclists.
- Principle 7 - Develop a varied density of development across the site. Create a variety of spatial settings and character such that variety and serendipity form a key feature.
- Principle 8 - Detail the site plan to such an extent that all features, utilities, amenity and practical usage are considered and planned.

4.3. PARAMETERS PLAN - AS DETAILED IN THE DESIGN AND ACCESS STATEMENT

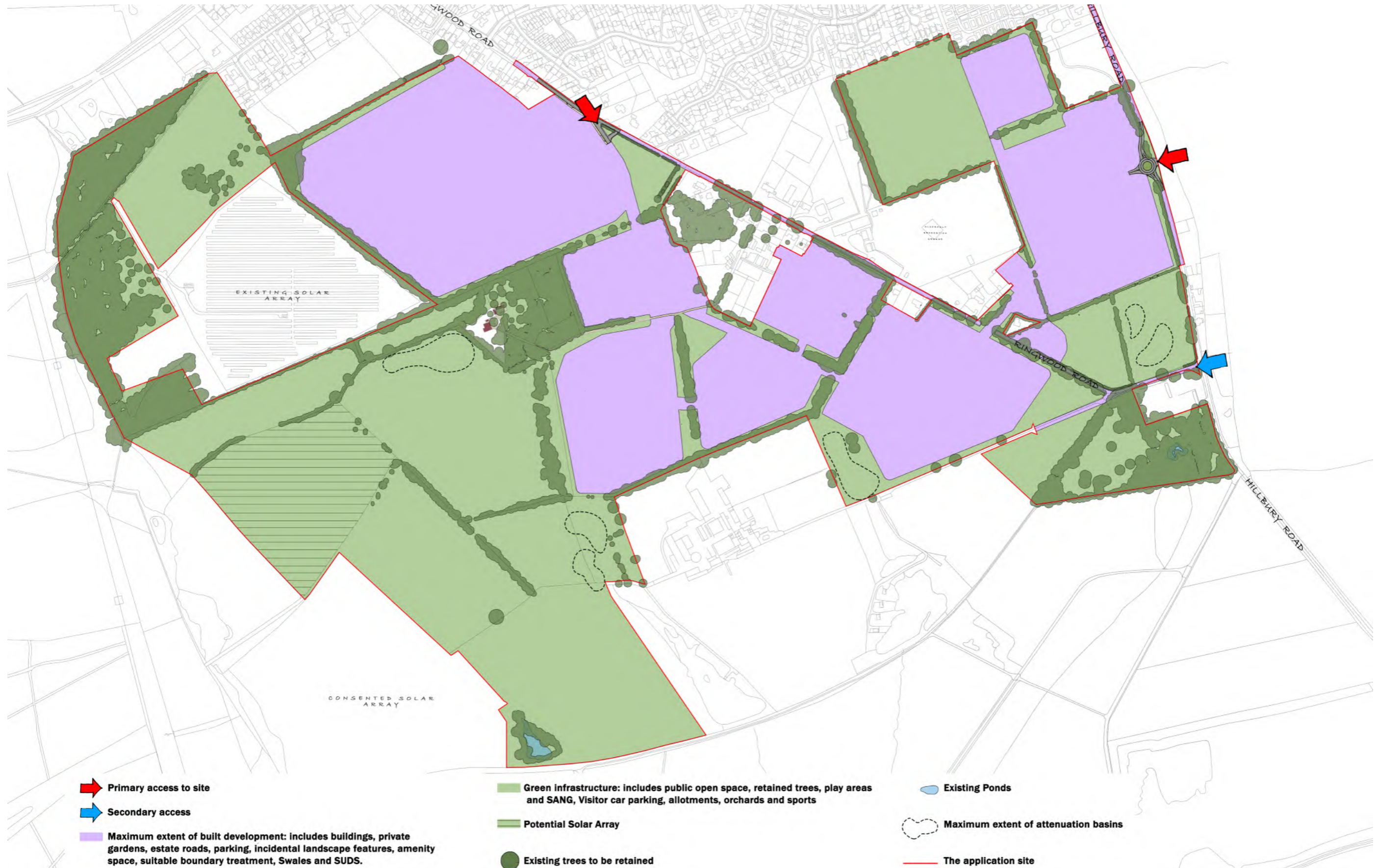

4.4. INDICATIVE LAND USE PLAN



4.5. INDICATIVE DENSITY PLAN



4.6. BLOCK STRUCTURE AND GREEN INFRASTRUCTURE

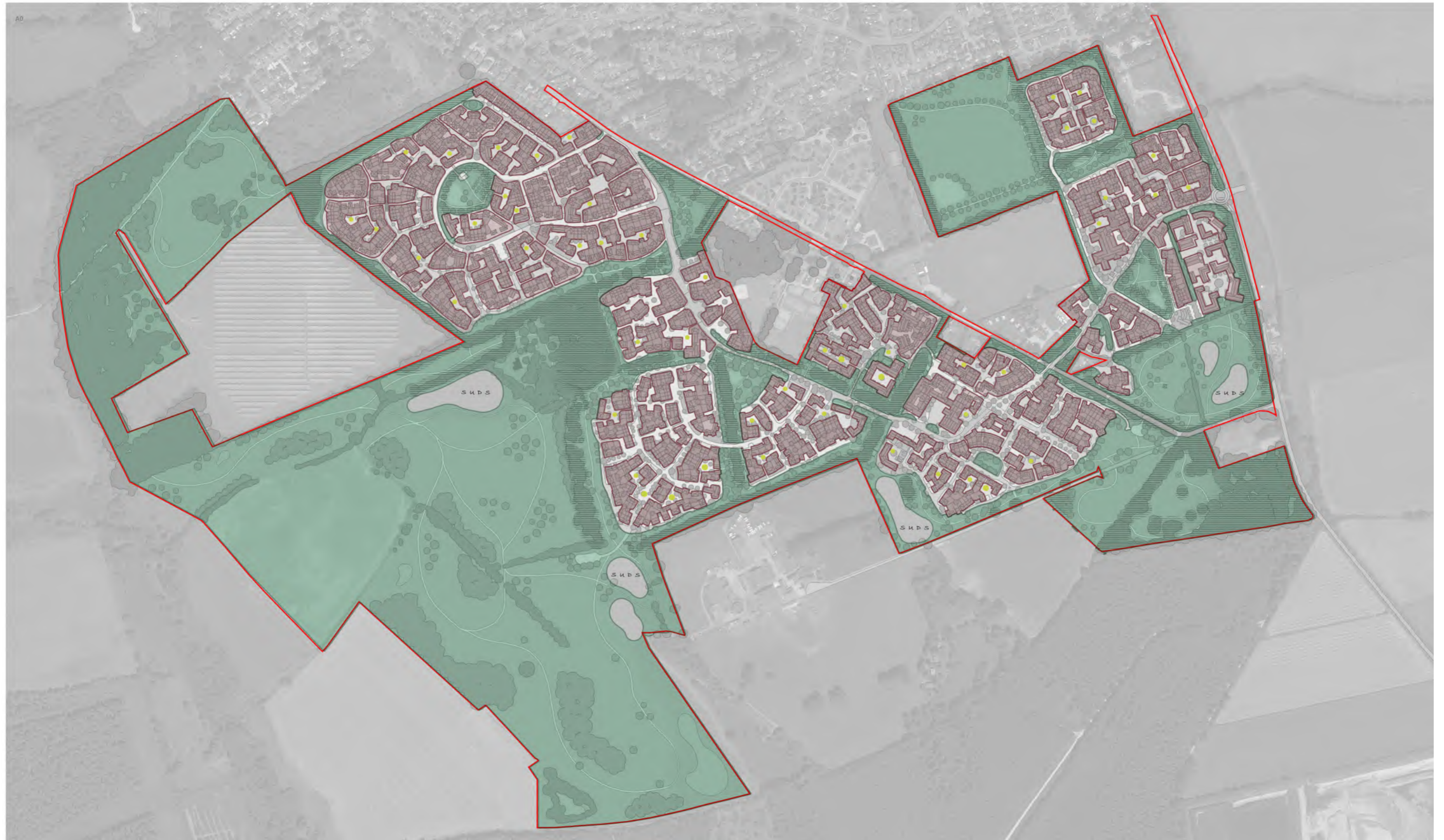



4.7. INDICATIVE MASTERPLAN



4.8. INDICATIVE MASTERPLAN - LOCAL CENTRE

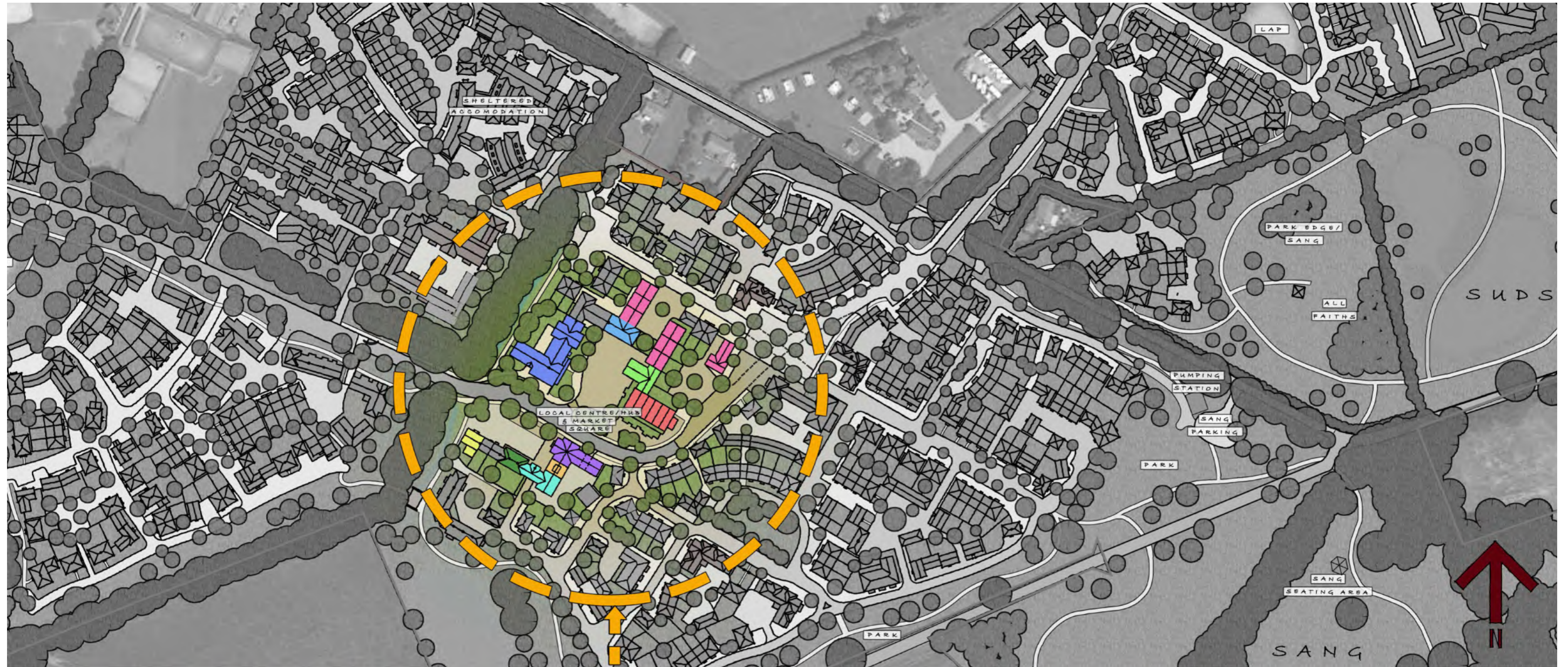

**ALDERHOLT MEADOWS LOCAL CENTRE, MARKET SQUARE AND HUB**

KEY:

- |   |   |  |
|---|---|--|
|  RETAIL/SHOP/COFFEE SHOP   |  PUBLIC HOUSE/RESTAURANT           |  DENTIST              |
|  VILLAGE STORE             |  BUSINESS ENTERPRISE/BUSINESS HUB  |  DOCTOR'S SURGERY     |
|  OFFICES/RETAIL/RESTAURANT |  COMMUNITY BUILDING + YOUTH CENTRE |  PHARMACY + OPTICIANS |
|   |  ESTATES OFFICE                    |  |

4.9. INDICATIVE MASTERPLAN - EMPLOYMENT LAND

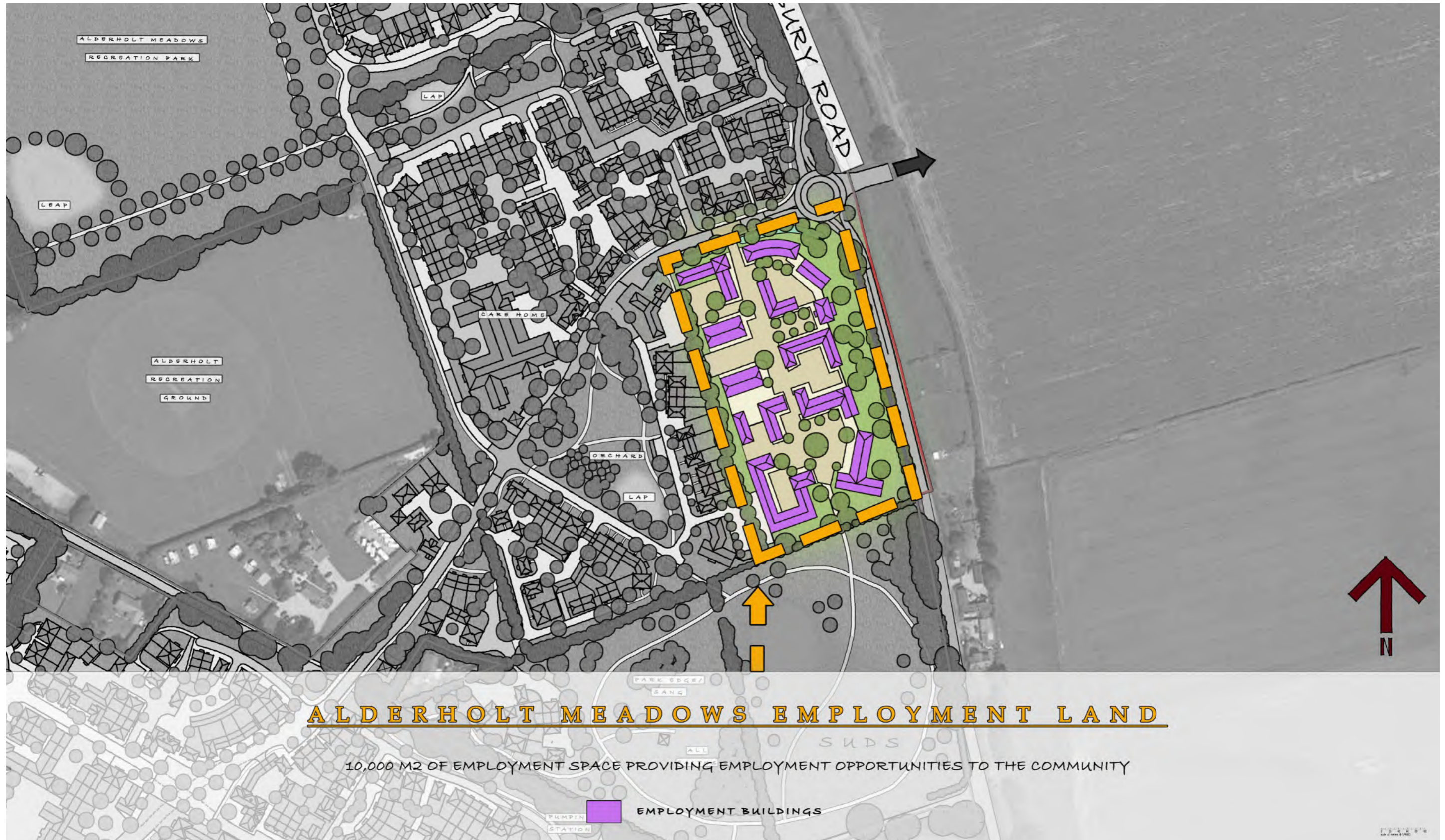

4.10. KEY BUILDINGS AND KEY FRONTAGES



-  Key buildings
-  Key frontages

#### 4.11. MORPHOLOGICAL STUDY

Morphology is a biological and linguistics term and is a process of analysis, used to describe the form and structure of body parts or words.

In urban design, it has much the same meaning and is a technique and process of analysis (often also called a “Figure Ground Study”) to consider the form, grain and structure of built footprints and the spaces they create.

Different morphologies produce different characters, and this analysis assists an urban designer in evolving a place creation and testing the design.

This process is where a diagram is produced, which shows only built footprints. This is then used to assess how the grain and spaces of built form appear and how they might relate to and convey a character of place.

A morphological study can be used just for a new development on its own, to understand its pattern, grain, and character or, in combination with an existing morphology to see how they relate.

In the context of the analysis included here, it has been generated to assess how the proposed grain and matrix of built form and spaces, shown within the illustrative masterplan, appears in combination with the existing settlement of Alderholt, and how they might relate, and be consistent with each other.

The key points are:

- Proposed design fits within the local spatial syntax.
- Density is consistent with that present in vicinity.
- Proposed scheme offers a pattern of spacious and organic plots.
- The character of the proposal is village like with a strong spatial identity.
- The scheme offers a continuation of the village and is designed for social interaction.



## SECTION 5 – LANDSCAPE STRATEGY

This section of the Design Code provides an overview of the Landscape Strategy for Alderholt Meadows. Further detail is provided in the Alderholt Meadows Landscape Strategy under separate cover.

### 5.1. LANDSCAPE OBJECTIVES

The plan for Alderholt Meadows is landscape led with homes and other facilities set within a rich landscape of grasslands, meadows, woodlands and wetlands. These will provide a fantastic resource for both the existing and future residents of Alderholt, and a haven for wildlife. The landscape strategy responds to the existing landscape assets both within the site itself and on adjacent land and has been generated around the following objectives:

#### 5.1.1. A CONNECTED LANDSCAPE

There are many walking routes within the wider countryside close to Alderholt but many of these are not well connected with the village. Our vision is to connect the routes delivering a much greater and more accessible green space network for Alderholt's residents, bringing improved access to nature and providing the essential green spaces in which wildlife can flourish.

#### 5.1.2. ENHANCING BIODIVERSITY

The natural features and the pattern of the landscape, the hedgerows, mature trees and watercourses will be retained and enhanced and new habitats will be introduced transforming farmland with relatively low biodiversity into a matrix of habitats that will support a rich wildlife. Provision of Suitable Alternative Natural Greenspace (SANG) will mitigate impacts on the protected heathland and provide attractive spaces for both people and wildlife close to new homes.

#### 5.1.3. A HEALTHY LANDSCAPE

Alderholt Meadows is planned and conceived to make walking and cycling the most attractive way to get around and to provide immediate access to a mix of open spaces and landscapes that will enhance the well-being and mental health of Alderholt's residents. A network of attractive and safe walking and cycle routes are proposed that will extend through the area and link with existing paths and public rights of way in the wider countryside. Children's play, fitness trails and public art will enhance the routes.

#### 5.1.4. SENSE OF PLACE

New homes will be laid out in distinct neighbourhoods and each will benefit from a neighbourhood park. In addition a larger Alderholt Park will be created on the northern edge of Alderholt Meadows adjacent to and doubling the size of the existing Alderholt Recreation Ground. These spaces will provide the settings for social interaction, play and local events and add to the sense of place in Alderholt Meadows.

#### 5.1.5. A BEAUTIFUL PLACE

The landscape will complement buildings to create a beautiful place. This will be achieved through careful design of every aspect of development and a creative and a coordinated approach to the whole place and its maintenance and management. The landscape will be designed to provide interest at all times of the year through a careful selection of plant species and a coordinated palette of materials will help to deliver a clear and distinct identity.

5.2. LANDSCAPE STRATEGY PLAN



### 5.3. A BEAUTIFUL PLACE

The Building Better, Building Beautiful Commission published its final report 'Living with Beauty, Promoting Health, Well-being and Sustainable Growth' in January 2020. One of its main aims and recommendations was to 'Ask for Beauty' in new development where 'beauty includes everything that promotes a healthy and happy life, everything that makes a collection of buildings into a place, everything that turns anywhere into somewhere, and nowhere into home.'

Alderholt Meadows will be a beautiful place and the landscape strategy will help to achieve this. At a strategic level this means taking a coordinated approach across the whole masterplan area and beyond; locally it means careful design that uses appropriate and robust materials in the design of the public realm and planting that is appropriate to the location providing both a physical, sensory and contextual response to the place.

Alderholt Meadows will provide a range of conditions and environments and the landscape strategy responds to this with a more informal/naturalistic approach taken to the design of the SANG areas on the site's periphery and a more formal approach to the streets and spaces within the residential neighbourhoods.

The quality of the landscape setting will be a defining feature of Alderholt Meadows helping to create a place with a unique identity and providing the link between the suburban character of the existing village and the open countryside, heathland, and woodland to the south and west. The broad aims of the landscape strategy are to:

- deliver high-quality landscape for play and recreation;
- retain and enhance the existing landscape and ecological assets;
- respond to flood risk and deliver a surface water drainage strategy that becomes a positive landscape feature within the development;
- enhance biodiversity and maintain ecological corridors through the site;
- mitigate impacts of recreational use on the European designated sites through the provision of extensive areas of SANG to the south and west of the site.





### 5.4. APPROACH TO LANDSCAPE DESIGN

The design of the landscape adopts the following principles:

- Use of native species contextual to the surrounding area wherever possible.
- Use of species that support wildlife - flowering and fruiting species.
- Specifying of species with consideration of their size and form at maturity and their maintenance and management requirements.
- Consideration of prevailing environmental conditions, soil type and drainage, and pest and disease tolerance.
- Avoiding large numbers of the same species in more formal areas to safeguard against the risk of tree losses through climate change, pest and disease.
- Providing a sensory experience through texture, colour, and smell throughout the year.

The landscape design will help to deliver sense of place, aid legibility and identity. Where there is space, on the main streets and within parklands, larger stature trees will be specified; within more intimate spaces smaller stature trees will be more appropriate.

Alderholt Meadows will be a green place and each home will include a tree (of appropriate size within its plot); the interface between properties and the public realm will be defined either by a low wall or hedge; and climbing plants will help building to blend into the landscape.

Herbaceous plants will be incorporated in planted areas in neighbourhood spaces delivering additional colour and scent through their flowers and attracting pollinating insects.



*Marsh marigold*



*Quercus robur*



*Rudbeckia species*



*Goat willow*



*Crataegus*



*Street trees*

5.5. PLANTING DESIGN

The quality of the landscape setting will be a defining feature of the development at Alderholt Meadows helping to create a place with a unique identity. The proposals retain the majority of the existing landscape features on the site including trees and hedgerows and supplement these with new planting that will enhance biodiversity, screen visual intrusion and establish an attractive setting for play and recreation. This new planting will be delivered as part of a wider landscape strategy of connected routes and spaces delivering green corridors that are both beneficial for people and wildlife.

Where appropriate, native species are promoted as this will enhance biodiversity. Consideration is also given to the dynamic nature of planting – living things grow, and appropriate choices must be made on which species should be planted and where.

The opposite figure identifies a range of tree species that are considered appropriate for the site and indicates where these should be located. This is by no means an exhaustive list and is provided as a guide at this stage.

Species	Main street	Secondary street	Minor residential street	Residential courtyards	Front gardens	Alderholt Park	Neighbourhood spaces	Swale corridors	Woodland planting (SANG)	Free standing trees (SANG)	New hedgerows
Acer campestre (field maple)		Yes	Yes	Yes						Yes	
Alnus cordata (Italian alder)	Yes					Yes					
Alnus glutinosa								Yes			
Amelanchier lamarkii (snowy mespilus)				Yes	Yes		Yes				
Betula nigra (river birch)								Yes			
Betula pendula (silver birch)				Yes	Yes		Yes				
Betula pendula 'Jacquemontii' (himalayan birch)				Yes	Yes						
Castanea sativa (sweet chestnut)						Yes					
Corylus avellana (hazel)									Yes	Yes	
Corylus colorna (Turkish hazel)		Yes		Yes							
Crataegus monogyna (common hawthorn)									Yes	Yes	Yes
Crataegus monogyna 'Pauls Scarlet' (hawthorn)			Yes		Yes						
Juglans nigra (black walnut)		Yes					Yes				
Pinus sylvestris (Scots pine)							Yes			Yes	
Quercus robur (oak)	Yes					Yes	Yes		Yes	Yes	Yes
Quercus robur 'Fastigiata' (fastigate oak)	Yes			Yes							
Salix alba (white willow)								Yes	Yes		
Salix alba 'Chermesina' (white willow)								Yes			
Salix caprea' (goat willow)								Yes	Yes		
Sorbus aucuparia sp (rowan)		Yes	Yes		Yes						
Tilia x euchlora (small leaved lime)	Yes										

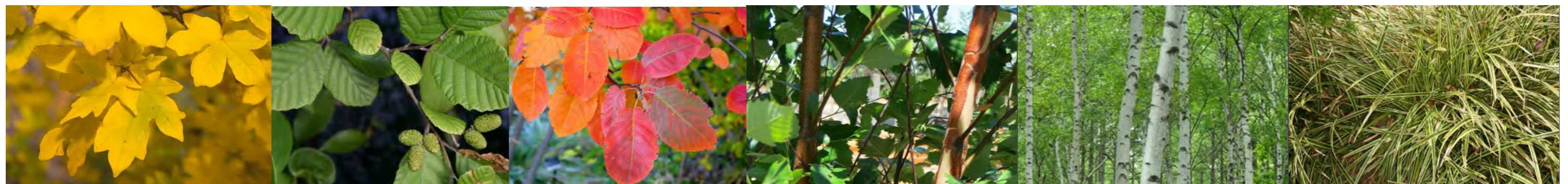

Acer campestre      Alnus glutinosa      Amelanchier      Betula nigra      Betula pendula      Carex



Corylus avellana      Corylus contorta      Pinus sylvestris      Salix alba Chermesina      Santolina chamaecyparissus      Symphoricarpos

## 5.6. AMENITY PLANTING

In addition to tree planting amenity planting at ground level will be hugely beneficial in enhancing the quality of the streetscape and residential amenity. The following principles are promoted in respect of amenity planting for Alderholt Meadows:

- A 2.5m wide margin planted with low growing shrub and herbaceous species is proposed alongside the main street delivering character and legibility to this street.
- Low growing planting at property interfaces within courtyard areas and where built form is used to define and enclose street spaces to soften the hard landscape within these areas.
- Shrub and hedge planting should be used to define property boundaries in combination with low brick walls or railings.
- Planting in public areas should generally be low growing to ensure that natural surveillance is retained.
- Species selected for both ease of maintenance but also to deliver year round colour, flowers and fruit that support wildlife and biodiversity.

Appropriate low growing species include Escallonia species, Hebe species, Hypericum calycinum, Lavandula species, Santolina species, Spiraea species and Symphoricarpos species. These supplemented by herbaceous perennial species including Ajuga, Heuchera, Rudbeckia, Salvia and Sedum species.

Appropriate hedging species include Acer campestre (field maple), Amelanchier lamarkii (snowy mesphilus), Carpinus betulus (hornbeam), Escallonia species, Ligustrum ovalifolium (privet) and Taxus baccata (yew).



## 5.7. URBAN WILDLIFE STRATEGY

Designing for wildlife will extend throughout Alderholt Meadows. Consideration will be given to providing habitats and homes for wildlife as part of the design of all parts of the development including the extensive areas of SANG and public open spaces and also within the more urban parts of the development as part of the buildings, streets, courtyards and gardens.

The selection of tree, shrub and herbaceous species will consider the wildlife they support. Wherever possible native plant species will be selected, and species that provide fruit or berries or a good source of nectar for insects will also be selected. The planting of a native tree is proposed in all rear gardens that exceed 10m in depth.

The lighting strategy has been designed to be sensitive to wildlife and in particular bats and to avoid light spill.

A range of further measures are proposed to support urban wildlife. This includes:

- integrated bat lofts, tubes, soffit boxes and bricks within the new dwellings and bat boxes within woodland and treelines;
- bird nesting boxes/bricks within dwellings;
- bee bricks within dwellings for solitary bees;
- fencing that is hedgehog friendly (providing gaps to facilitate movement).



Bee bricks

### 5.8. LANDSCAPE AND VISUAL IMPACT SUMMARY

A landscape and visual impact assessment (LVIA) has been prepared to determine the likely effects of the proposed development. The LVIA addresses the following landscape resources and visual receptors:

- landscape character, including physical landscape resources;
- views and visual amenity experienced by residents, recreational users and road users.

The LVIA identifies the key constraints and opportunities present in the site and surrounding landscape, and also the nature of the likely impacts that may arise from the proposed development. The LVIA has analysed the baseline information in the context of the proposed development and has subsequently considered proposed mitigation measures that have been used to inform the design of the proposed development. The mitigation forms an integral part of the design and masterplan.

There is comprehensive coverage of landscape character at a regional and local level through published landscape character studies. The Landscape Effects have been considered in the context of these studies.

The visual envelope for the site was established through desk-top and on site analysis informed by establishing a ZTV (Zone of Theoretical Visibility) and is defined by the approaches towards the site and views from road infrastructure, from recreational routes including the network of Public Rights of Way and non-designated footpaths in the wider area and also by residential receptors in properties in Alderholt that look towards the site.

Constraints and opportunities have been identified on the site. Along with an analysis of the proposed development and the early identification of likely landscape and visual impacts, these have been used to develop the design of the proposed development and to form a comprehensive landscape strategy.

The physical landscape impacts that will give rise to perceived changes in landscape character are generally limited to some loss of vegetation within the site to achieve access and the changes to the land use associated with the proposed development. The landscape strategy (and overall masterplan) aims to retain and enhance the characteristic elements and features of the area, including the pattern and scale of hedgerows and the existing trees.

Impacts will be mitigated through significant additional areas of planting throughout the Alderholt Meadows area including as part of swale corridors and new public open spaces.

In addition significant new planting is proposed as part of the delivery of two SANG areas in the western and south-eastern parts of the site. This will include new areas of woodland, scrub and tree planting, wild flower meadows and wetland areas and is intended to compliment the habitats and landscape character on Cranborne Common and Ringwood Forest to the west and south and to enhance biodiversity.

A range of representative visual receptors have been used to inform the LVIA. These include:

- recreational receptors such as walkers, cyclists and horse-riders using Public Rights of Way and permissive footpaths within the wider area including from Cranborne Common, the northern edge of Ringwood Forest and from farmland to the east of the site;
- road users, including those using Ringwood Road, Hilbury Road and the smaller lanes to the east of the site;
- residential receptors from residents living in properties that overlook the site.

Fifteen representative viewpoints were selected informed by the ZTV and site visits. For each viewpoint a sequence of visualisations have been prepared. These are:

- existing Winter view (April 2022)
- existing Summer view (July 2022)
- Year 1 Composite View
- Year 15 Composite View
- Year 1 Photomontage View
- Year 15 Photomontage View.

Consideration has also been given to the potential visual impacts of the proposed development on residential receptors i.e. for all homes that look directly onto the site.

The impacts on receptors has been assessed in the LVIA (refer to ES Chapter 8 and Appendices 8.1 to 8.6). Overall the selected viewpoints and subsequent analysis demonstrate that the site and proposed development will be visible from a localised area only and where it will be seen, the highest degree of adverse effects are limited to views on, or immediately adjacent, to the site only.

The most significant visual effects are from the northern edge of the site on Ringwood Road (viewpoint 7) and for residential receptors in the eleven properties at the northern end of Ringwood Road and two further properties further south on Ringwood Road (opposite Foxhill Farm) that back onto the site. From each of these locations there will be visual effects with a predominantly open green view replaced by a view across new housing. These changes have localised impact and are not in themselves unattractive.

On completion at year 1 there will also be visual impacts from viewpoints on Hilbury Road (Viewpoints 1 – 3), and from other viewpoints on Ringwood Road (Viewpoints 4 - 6). Significant planting proposed as part of the landscape strategy for the site will help to reduce visual effects so that the magnitude of these impacts will reduce as new planting establishes (Year 15).

Furthermore the development has been planned to ensure that from each of these locations residential development, and the landscape framework within which it is located, is laid out to create a strong sense of place that respects the existing landscape character.

The cumulative impacts of the proposed development and a proposal for 45 homes on the former Hawthorns nursery site on Ringwood Road have also been assessed. Whilst the magnitude of visual impacts on some receptors will increase this will have a minor impact only.

5.9. STRUCTURAL TREES



## SECTION 6 – STREETS AND MOVEMENT

The street hierarchy and the means of movement into and within the site have been defined to create a legible living environment where the impact of the car is managed, visually reduced, all in a positive manner through design.

A fully integrated and considered provision is made for pedestrian and cycle users to promote all models of transport and activity/ leisure.

### 6.1. PRINCIPLES AND DEFINITIONS

The road, cycle and footpath network will be defined through the application of principles relating to:

- **Street hierarchy**
- **Pedestrian and cycle access**
- **Car parking**

The principles identified within this section will be applied in general terms across the site in order to provide structure and clarity to the layout and to provide safe and convenient patterns of movement.

### 6.2. STREET HIERARCHY

The primary highway network will be designed to an adoptable standard in terms of access and manoeuvrability. To avoid the restricted use of limited hard surface treatments which are estate like, it is anticipated that, to allow the flexible application of design requirements, particularly in respect of landscape provision and the use of hard surface materials that, the maintenance and management of some of the communal areas and hard surface environs will be set within a management company and where all households within the development contribute toward the general maintenance and upkeep. This will allow where appropriate the use of gravel, stone setts, flag stones and countryside kerb setts in lieu of tarmac and concrete.

Within this section, the street hierarchy is outlined, and the essential design principles of each street type are described with respect to general dimensions, materials, street trees, street furniture and boundary treatments.

#### 6.2.1. THE STREET HIERARCHY COMPRISES:

- **Access road**
- **Primary street**
- **Secondary street**
- **Tertiary street**
- **Courtyards/shared surface areas**
- **Private drive**
- **Green link**

The position of the main access roads and green links are essentially fixed by the development parameters and their location is illustrated on the masterplan. The other elements of the hierarchy can be applied throughout the site as a part of the master plan evolution/each RMA.

The main access road can be tarmac and with set margins. Street trees, varied textures, shared surfaces and separated pedestrian routes will all assist and preserve/enhance the current character and the prospect of a characterful place that sits within pockets of a periphery of trees and wider landscape setting. Vehicle speeds should be low and with speed control, achieved through the street character, changes in street alignment and limiting forward visibility. For private drives and small areas of development up to 5 dwellings, hard surfaces should be organic and not tarmac. See Detailed Section - SECONDARY ROUTES and materials schedule.

#### 6.2.2. CAR PARKING

Car parking is an integral feature of the detailed design. Generous provision has been made on plot and within the courtyard areas to minimise/negate the need for significant on-street parking.

Where on street parking is necessary, this has been designed into the road layout and provision made to prevent vehicles parking in undesirable locations or where they could block key vehicles, such as refuse, ambulance or fire trucks. Creating a masterplan which negates the need for a car dominated scheme and which allows for a total provision, without allowing the same to be a strong feature of the design character, is an essential feature of new urbanism and a character which is more historic.

6.3. STREET HIERARCHY PLAN





## 6.4. PRINCIPLES AND DEFINITIONS – STREET HIERARCHY

The following design sketches / diagrams have been produced to portray a broad range of street and movement conditions to primary, secondary, tertiary and courtyard / mews conditions.

They should be read alongside current government guidance (MfS1 and 2). Although not mandatory the design intent explained within CABI publications “Design Bulletin no 32” and “Places, Streets and Movements”, still offer qualitative guidance in relation to urban design and place making and should be referred to.



6.5. TYPICAL STREET SECTIONS

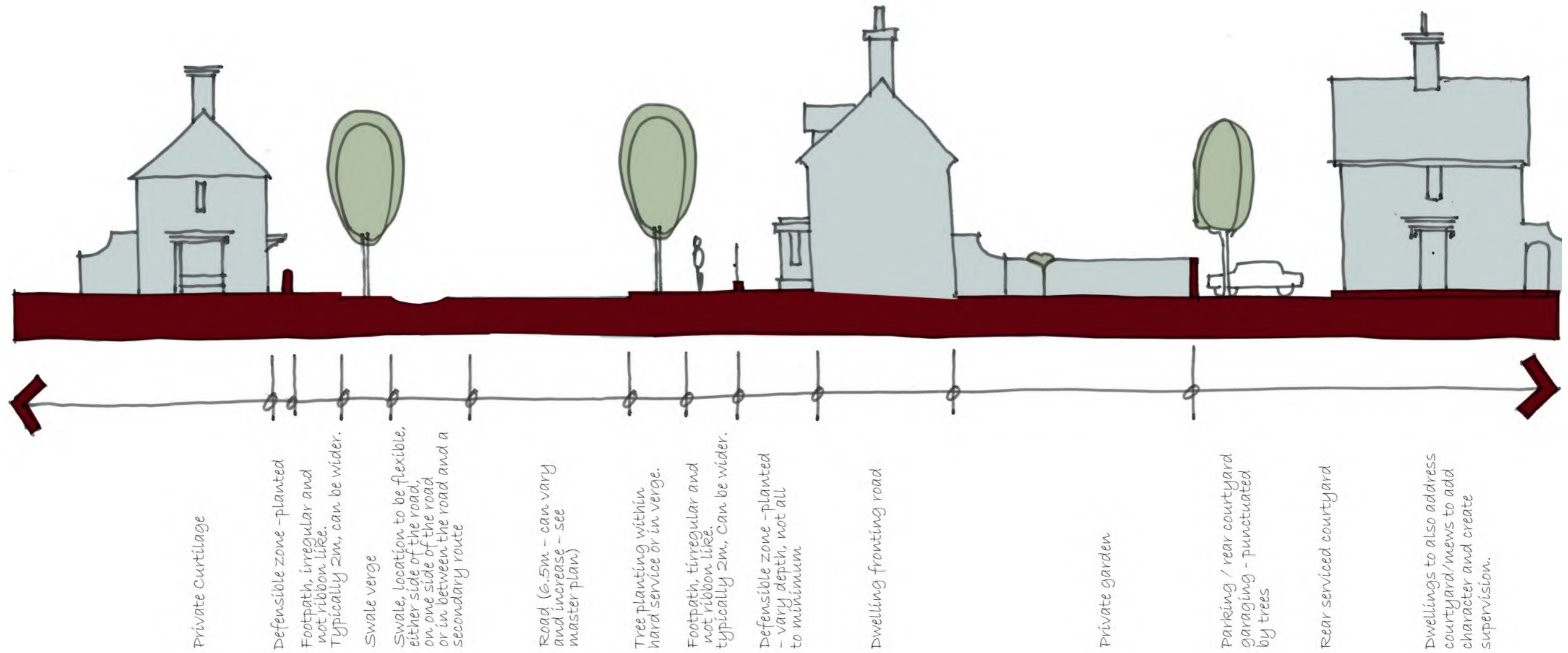

Street Section A - Primary Road/with Swale & Street Trees

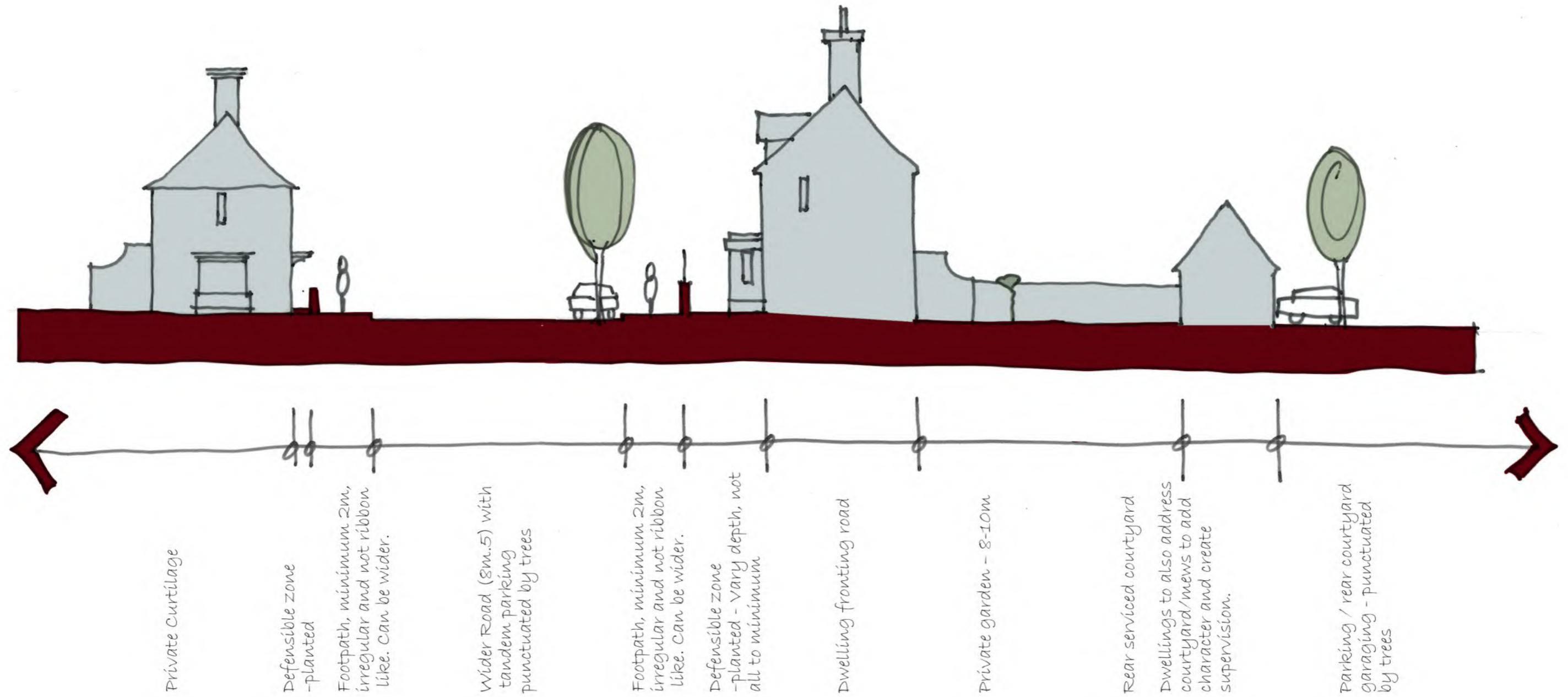

Street Section B - Primary Road/with Street Trees & Parking

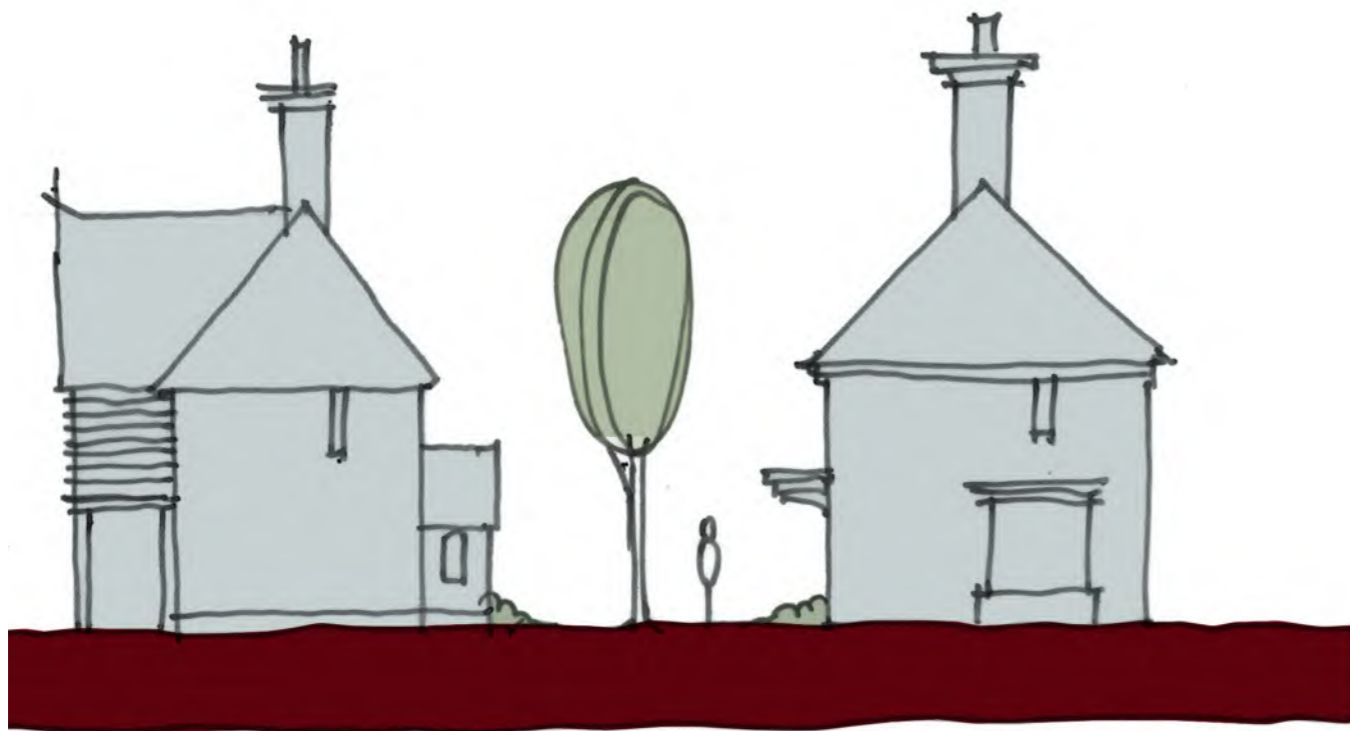

- Tree planting
- Organic sensation
- Defensible zone to be amorphous
- Buildings to address spatial sensation  
- no blank facades

Street Section C - Tertiary – Pedestrian only

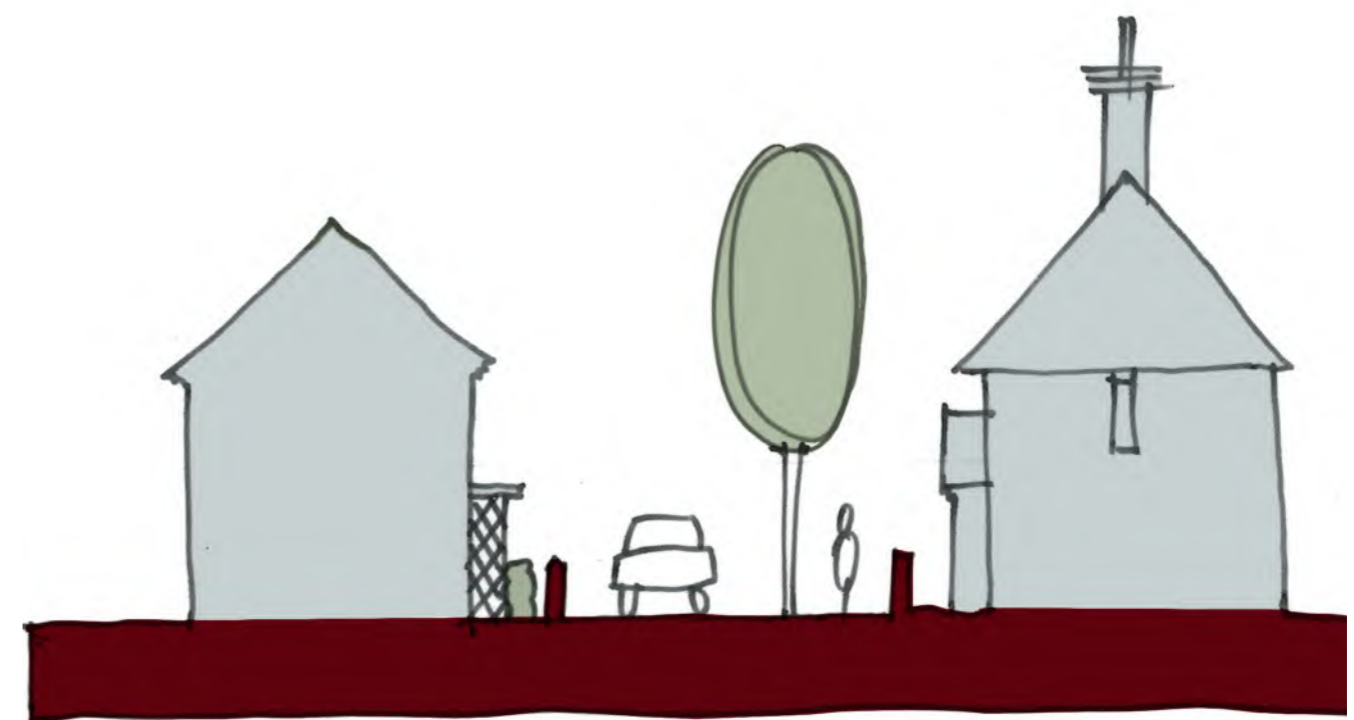

- Tree planting
- Defensible zone to be amorphous
- Trees define route for pedestrians and demarcate that for the car
- Buildings to address spatial sensation  
- no blank facades
- Organic sensation

Street Section D - Tertiary – single car access and pedestrian only

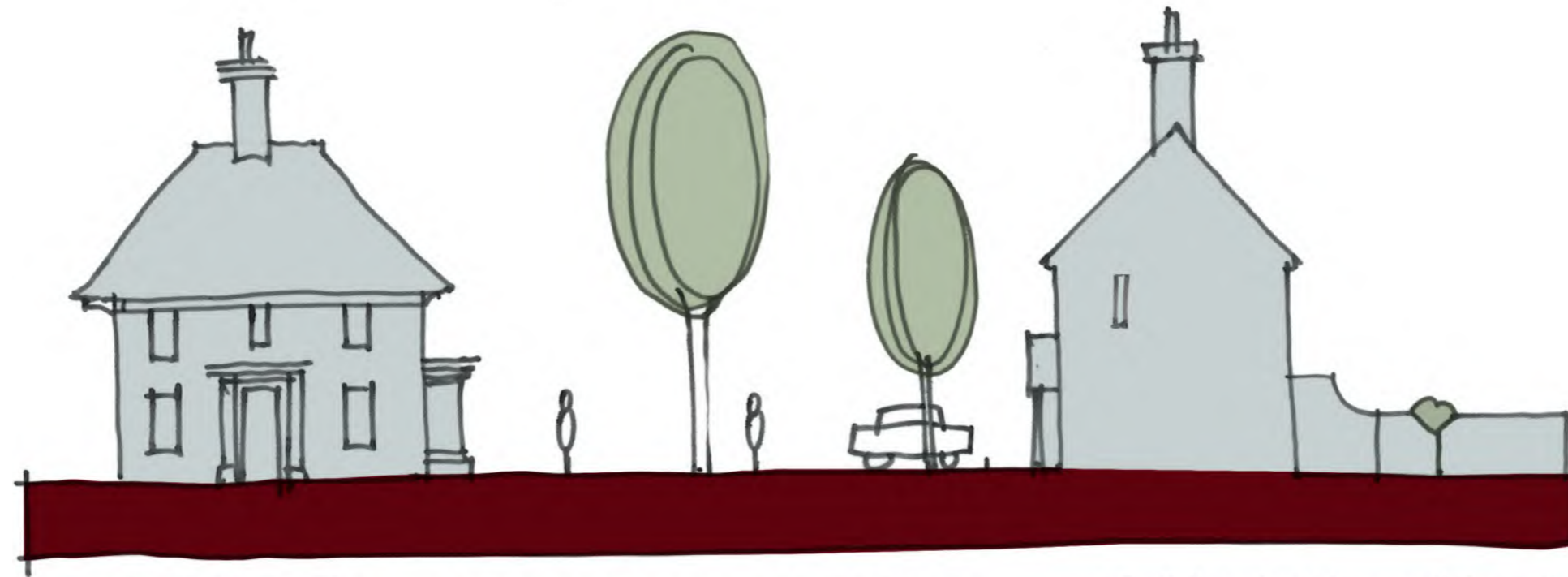

- Organic sensation
- Central character tree
- Tree planting to punctuate parking
- Defensible zone to be amorphous
- Trees define route for pedestrians and demarcate that for the car
- Cars and pedestrian share the space
- Buildings to address spatial sensation - no blank facades

Street Section E - Mews Court/Courtyard/Parking Court

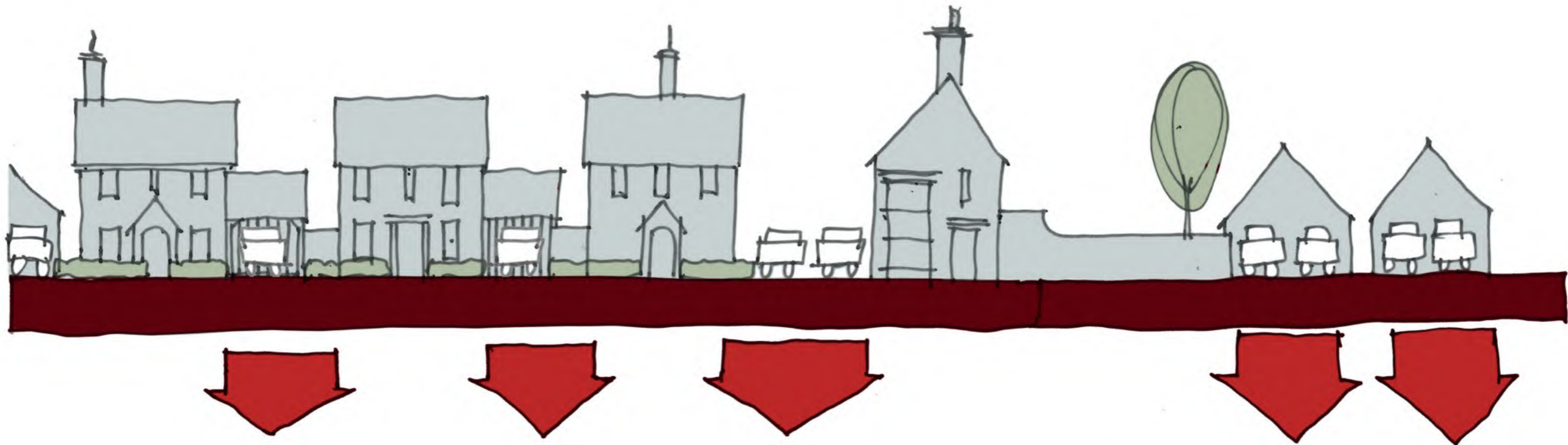

The conventional and estate-like urban design format, where the garage and parking proliferate and dominate the street scene should be avoided. Occasional frontage courts with recessed garaging will be permissible however these should be considered within the setting of the street scene and the dwelling. The use of piers, gates, high-quality hard surfaces, and landscaping, as well as garage design which can be a part of the architecture, should be applied, to diffuse. A conventional house/garage-house/garage arrangement as shown will be permissible. See Design illustration G.

*Street Section F - Car/parking dominated street scene –Conventional back to back block structure with parking within curtilage.*

**Such design format should be avoided.**

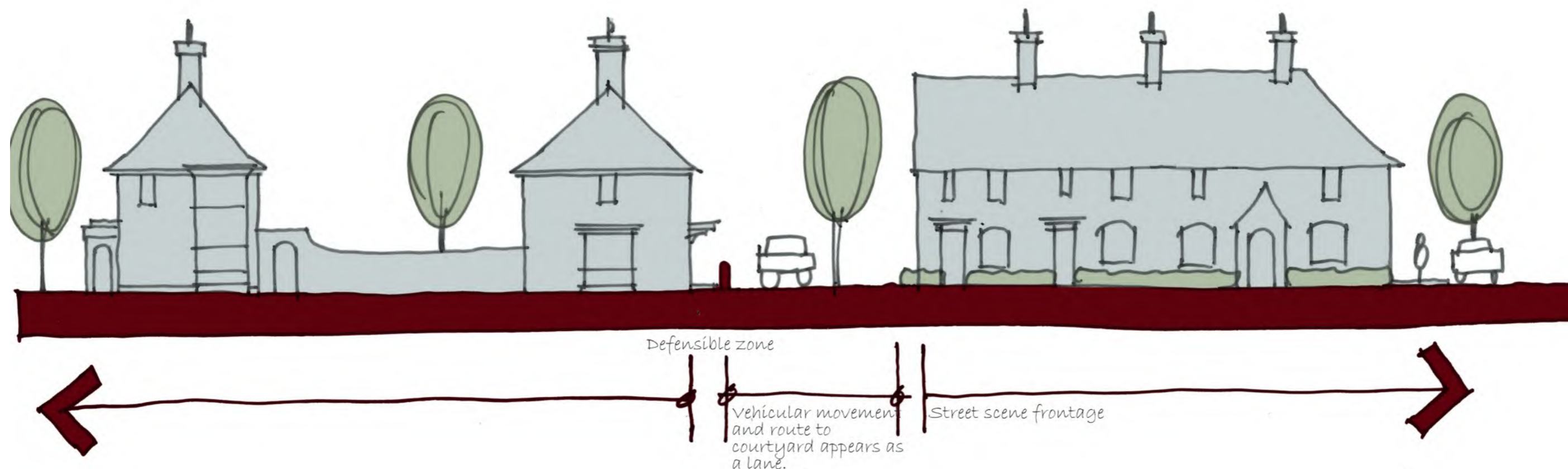

In line with MFS 1 & 2, the use of rear serviced courtyards should be applied to alleviate the dominance of cars and car parking/garaging.

These can exist alongside frontage parking ( see design sketches A-F) but the latter should not dominate.

A rear serviced courtyard creates facility whilst releasing the street scene to achieve full architectural effect and emancipated from the estate like format of the street trying to include garaging/driveways to most dwellings. The mews/Court beyond can contain the vast majority of parking however, some frontage parking within the street is permissible.

Within these mews/court areas the proximity of dwellings/architecture and planting/structure trees is important to again, diffuse the dominance of the car and a character which is solely t

See Design sketches A - F.

Occasional frontage courts with recessed garaging will be permissible however these should be considered within the setting of the street scene and the dwelling.

The use of piers, gates, high quality hard surface and landscaping, as well as a garage design which can be a part of the architecture should be applied, to diffuse.

*Street Section G - Car/parking located within a rear serviced courtyards/mews areas*

## SECTION 7 – LIGHTING STRATEGY VISION

### 7.1. GENERAL

The lighting strategy for the Alderholt Meadows development takes an approach that is both sensitive to the environment and to the style of the development itself.

The lighting strategy takes a considered approach to the environment, basing the selection of the lighting levels on the needs of those living within and visiting Alderholt Meadows, and balancing this against the sensitive condition of the surrounding landscape.

### 7.2. LIGHTING HIERARCHY

Within Alderholt Meadows there are several classes of roadway/pedestrian routes. Each of these requires a different approach to lighting that provides for the needs of those using these areas while giving the development a sense of place and cohesion.

Cohesion across the development will be maintained by the luminaire and lighting column style along with the colours of light used.

All lighting within Alderholt Meadows will be of the warmer colours of light, thus fitting with the aesthetic of the architecture, providing a comfortable environment that fits with the rural area, and providing protection to the environment.

The different classes of road are distinguished within the lighting strategy based on the required lighting levels needed to ensure the safety of those using these areas, and how the lighting within these areas will be controlled. The hierarchy of lighting is as follows:

1. Main Junctions
2. Primary Road
3. Secondary and Tertiary Road

The two main junctions (Ringwood Road and Hillbury Road) will require the highest levels of lighting of the roadways within Alderholt Meadows. These areas will require lighting throughout the night, but they will conform to the requirements for cohesion and sense of place.

The Primary Road will also require lighting throughout the night, but will require a reduced level of lighting compared to the Hillbury Road Junction.

Within the Secondary and Tertiary Roads lighting will be provided using lower column heights compared to the Primary Road and will use a part night switching regime.

Lighting for the Main Junctions, Primary Road, and the Secondary and Tertiary Roads will be provided at a recognised standard level. The locations of lighting columns will inform the wayfinding element of the design, with locations being selected to both provide a coherent path through the different areas of Alderholt Meadows, while meeting the requirements of the differing areas of the development.

Zone	Surrounding	Lighting Environment	Examples
E0	Protected	Dark (SQM 20.5 +)	Astronomical Observable dark skies, UNESCO starlight reserves, IDA Dark Sky Parks
E1	Natural	Intrinsically dark (SQM 20 to 20.5)	Relatively uninhabited rural areas, National Parks, Areas of Outstanding Natural Beauty etc
E2	Rural	Low district brightness (SQM ~ 15 to 20)	Sparsely inhabited rural areas, Village or relatively dark outer suburban locations
E3	Suburban	Medium district brightness	Well inhabited rural and urban settlements, Small town centres or suburban locations
E4	Urban	High district brightness	Town / City centres with high levels of night-time activity

Table 1: Environmental zone descriptions

Environmental Zones	Sky Glow ULR (Max %)	Light Trespass (into Windows) E <sub>v</sub> (lux)		Building Luminance Average, Pre-curfew
		Pre-Curfew	Post-Curfew	Average L (cd/m <sup>2</sup> )
E0	0	0	0	0
E1	0	2	0 (1*)	0
E2	2.5	5	1	5
E3	5	10	2	10
E4	15	25	5	25

Table 2: Obtrusive light criteria relating to each environmental zone.

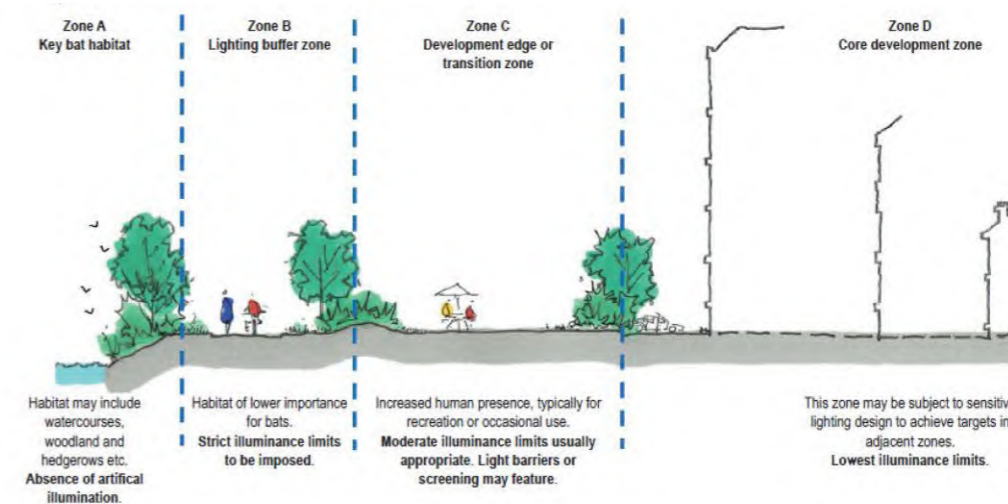

Illumination limitation zones outlined in GN08:18



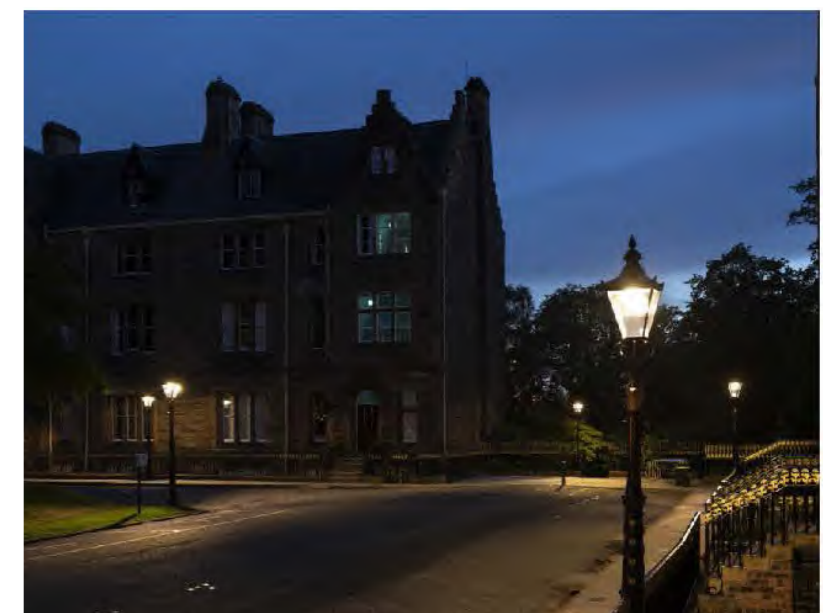

Concept Images

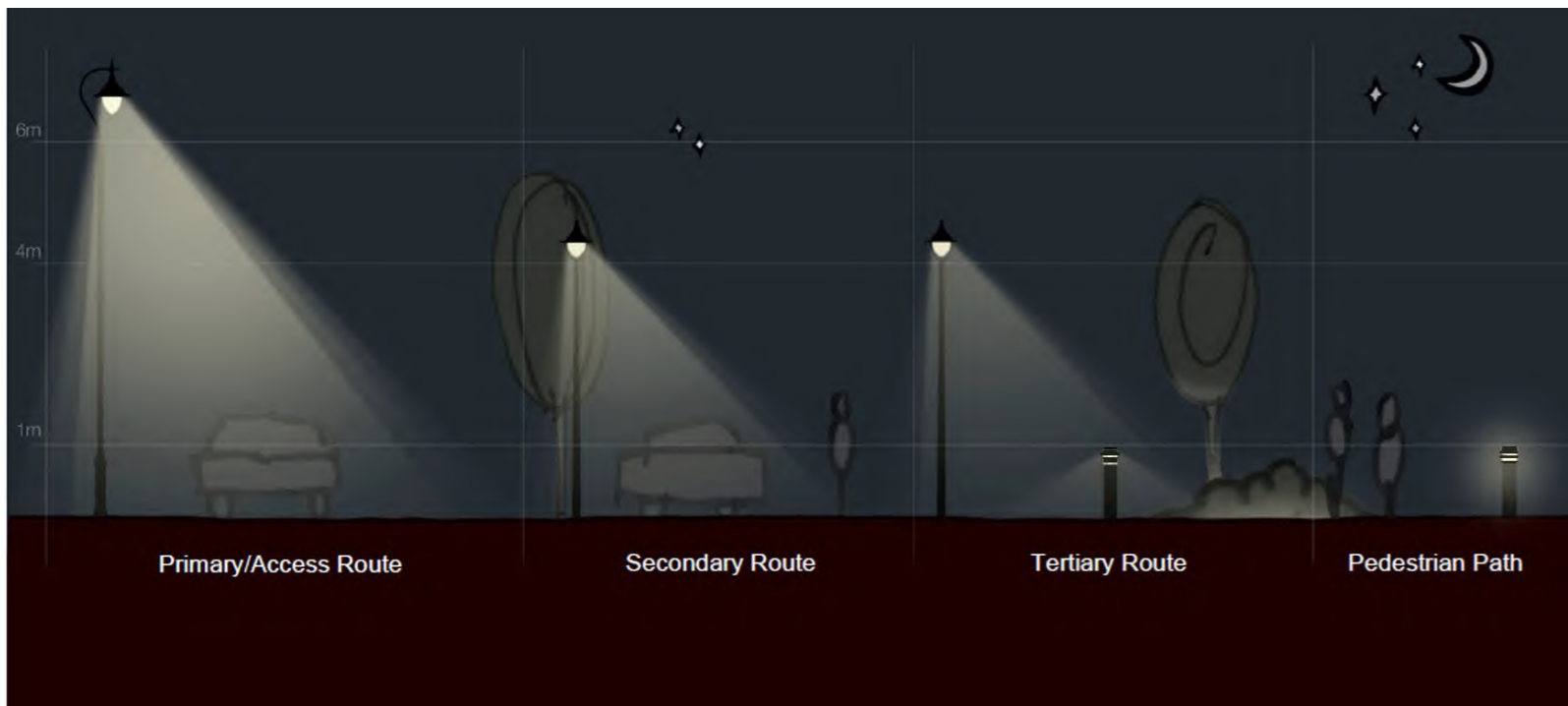

Lighting hierarchy

Shielded bollards



Heritage style lantern in painted black/ black iron



Tear drop 'U' bracket, in same finish as lantern

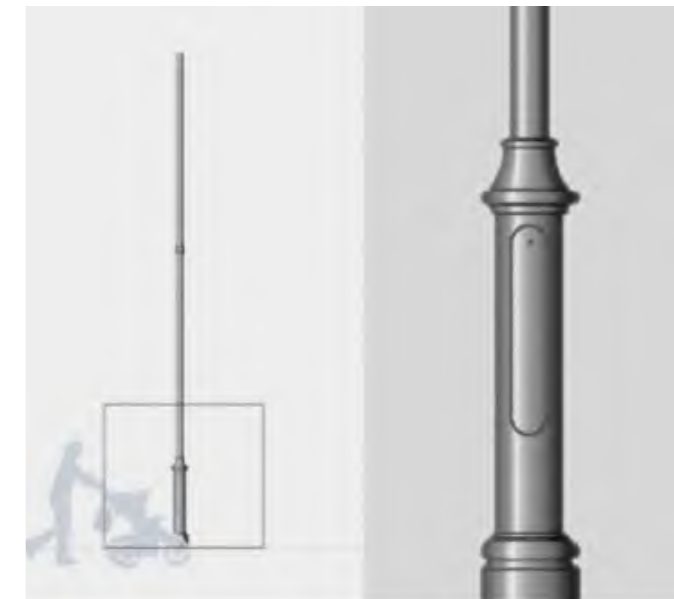

Column with Heritage Pedestal

## SECTION 8 – APPEARANCE

### 8.1. BUILDING

The nature and form of the buildings within the site will make a significant contribution towards the character and essential quality of the development. The scheme will seek to deliver distinctive buildings that bring together functionality and high-quality appearance. This will be achieved through the application of simple design principles and an uncomplicated palette of materials. In essence, all should fit within the vernacular and be invested in detail, cognition, and quality. Diluted pastiche will not be acceptable.

### 8.2. BUILDING DEFINITIONS

The range of buildings to be provided on the site will comprise dwellings and appropriate ancillary buildings and structures, such as garages and car ports.

To guide the creation of these dwellings, indicative house type designs have been shown. These are included here to found the architecture into a formal and conditioned document. Each form has a scale and that scale relates to the built form on site. The range is 1, 1 ½ (garages and subservient buildings) and 2, 2 ½ and 3 ½ storey for residential, set within traditional proportions. Samples are given within this code along with indicative elevations that draw from the local vernacular.

It is also recognised however, that the evolution of the design process does not begin and end at the commencement of the masterplan and this code. Opportunities will be taken to further consider the design and internal layout of units as the scheme progresses, with the Design Code supporting innovation, market response and new ideas as ongoing parts of the design process are achieved and submitted for assessment in any sequence of reserved matters submissions.

In terms of the mix of the building types across the site, there should be a specific and purposeful pursuit towards family housing and dwelling types that suit a range of need. A variety of size and extent of connect and detachment, as well as a variety of scale, enables a hierarchy.

This hierarchy will add to the character of place and enable key buildings to sit in small groupings, arranged into various street hierarchies, lanes, courtyards, small mews areas, private drives and car free routes. Creating “pockets of place” that connect with variety and interest is an essential feature of the masterplan and it’s interpretation of the Dorset vernacular and typical village morphology.

### 8.3. DETACHED

The provision of detached units will be a predominant typology, featuring throughout the scheme. A varied range of sizes, orientations and designs will be used to create attractive street scenes and distinctive elevations.

The detached units will give due regard to the following:

- The siting and orientation of the dwellings within the street scene will be given particular attention, using formal and informal layouts to promote character.
- Variety will be provided through different elevational treatments.
- The internal layouts will provide a flexible space, particularly in larger units, with the provision of spaces such as studies and utility rooms.
- Opportunities will be taken to create distinctive individual units in key locations.

### 8.4. SEMI-DETACHED

The provision of semi-detached units will be a typology used to provide variety in the street scene. Whilst used sparingly through the scheme, they can assist in balancing street scenes and fitting in with other combinations, lower range/subservient structures. Semi-detached forms can take the form of linked detached and where the connection is made by a more subservient form such as a lower range of garage that has the sensation of an outbuilding OR as a designed set piece, where the buildings do unite with either a planned symmetry OR with variance in architectural treatment/scale. See sample elevational designs.

The semi-detached units will give due regard to the following:

- The siting and orientation of the dwellings within the street scene will be given particular attention, using formal and informal layouts to promote character.
- Variety will be provided through different elevational treatments.
- The units will be balanced and will be designed to fit within the wider street scene.

### 8.5. TERRACED

The provision of terraces should be predominantly of two-bedroom units but with the occasional use of 3 bed units to act as a stop end /create variety. Typically, terraced units should not extend for more than 5-6 units.

A small terrace can be used to set a view, create a spatial sensation/sense of enclosure or, provide a feed into a courtyard. By combining 3-6 homes into one cohesive and considered form, a greater architectural effect and sense of arrival is afforded and, whilst being the smallest in size, of the homes planned, they are in a unity and of great importance to the scheme and its character.

The terraced units will give due regard to:

- The siting and orientation of the dwellings within the street scene will be given particular attention, using formal layouts to promote character.
- A considered single elevational treatment to create unity and dialogue, within the family of architectural design planned.
- The units will be balanced and will be designed to fit within the wider street scene.

8.6. PLAN FORM

The plan form is the two-dimensional pattern arrangement of each home/building. These will join to form development blocks, streets, and spatial settings. The form of the new development needs to draw from local vernacular typologies with traditional or contemporary interpretation.

8.6.1. DETACHED PLAN FORMS

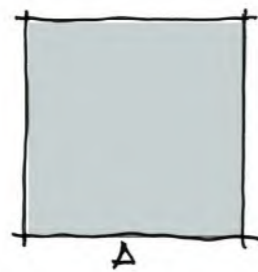

1. Squared

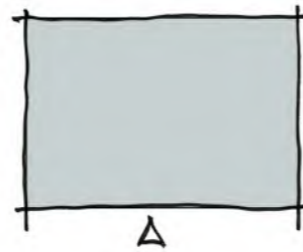

2. Wide frontage



3. Narrow frontage

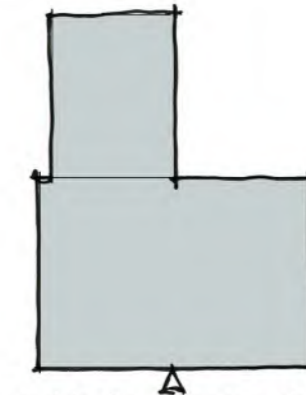

4. Wide frontage 'L' Shape  
Rear wing  
Pattern floor plan - corner turner



5. Squared - set as diamond  
Axial form

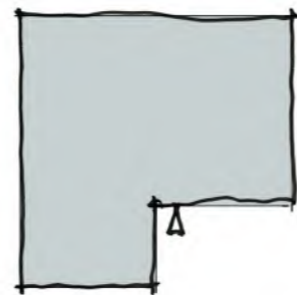

6. 'L' shape, frontage wing  
Pattern floor plan- Bookend  
recessed door

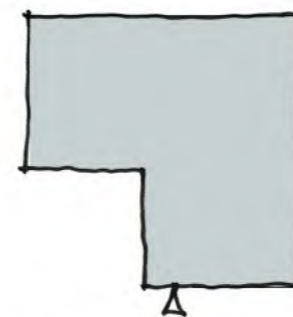

7. 'L' shape  
Pattern floor plan  
Feature door

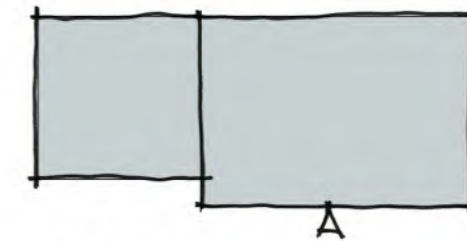

8. Wide frontage, lower scale side wing

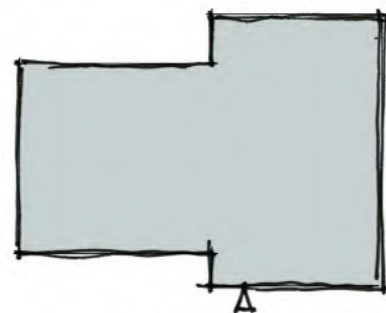

9. Pattern floor plan - T plan  
(or handed)

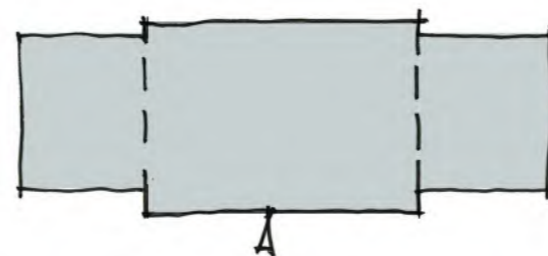

10. Wide or squared, 2x side wings  
Axial form

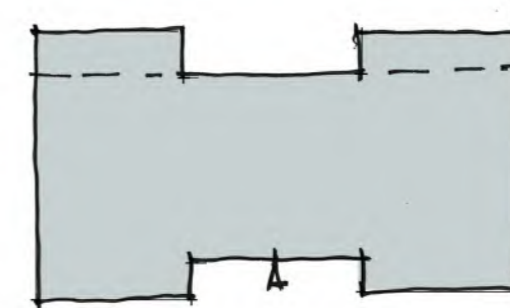

11. 'H' Shape  
Pattern floor plan - Bookend

8.6.2. SEMI-DETACHED PLAN FORMS

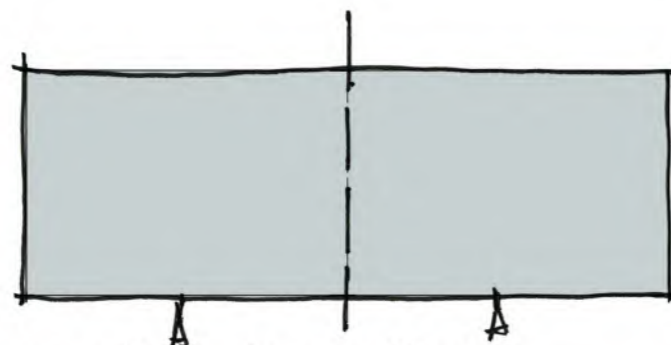

12. Wide frontage combined

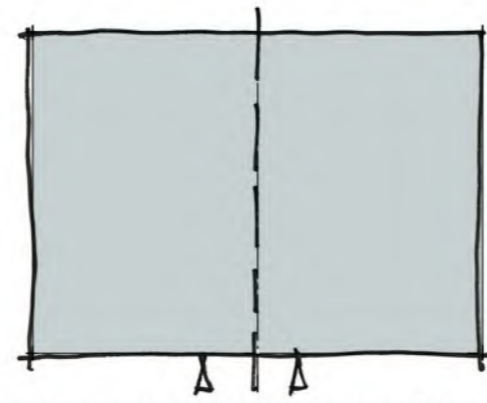

13. Narrow frontage combined

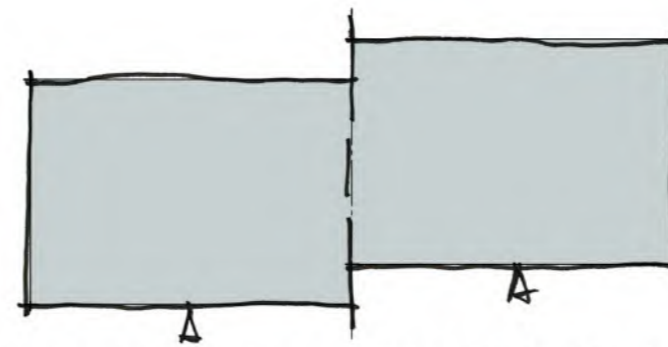

14. Wide frontage combined/split frontage

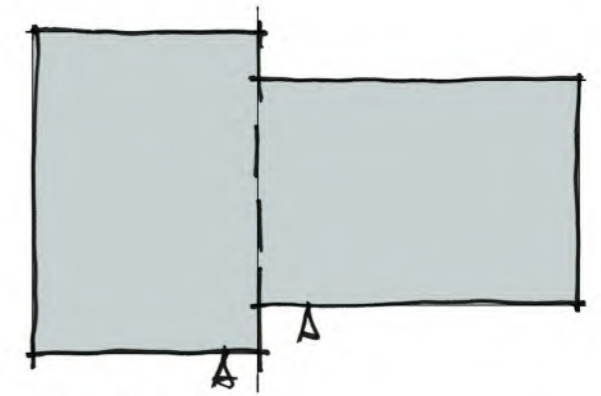

15. Bookend  
wide / narrow frontage combined

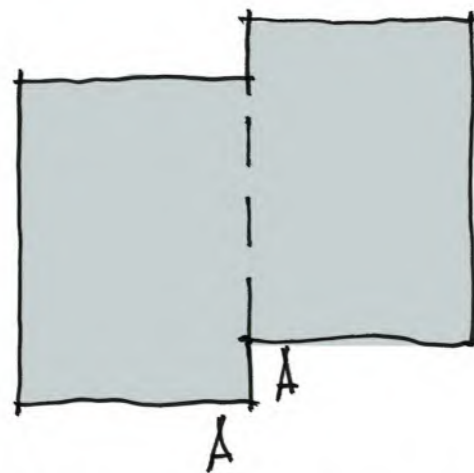

16. Narrow frontage combined/  
split frontage

8.6.3. TERRACED PLAN FORMS

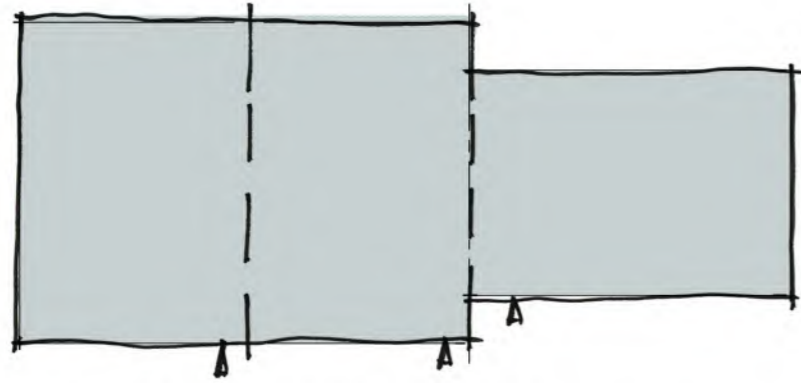

17. Combined shapes (terrace of 3 Max.)  
Narrow frontage / wide frontage combined

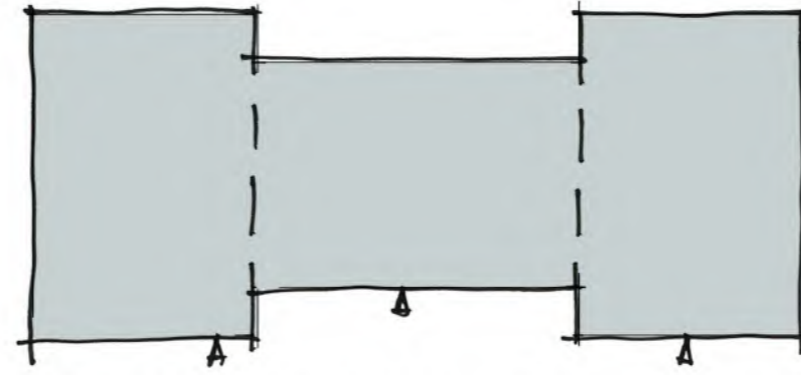

18. Combined shapes (or handed)  
'H' shape, Pattern floor plan (terrace of 3 Max.)  
Bookend both ends  
wide frontage / narrow frontage combined

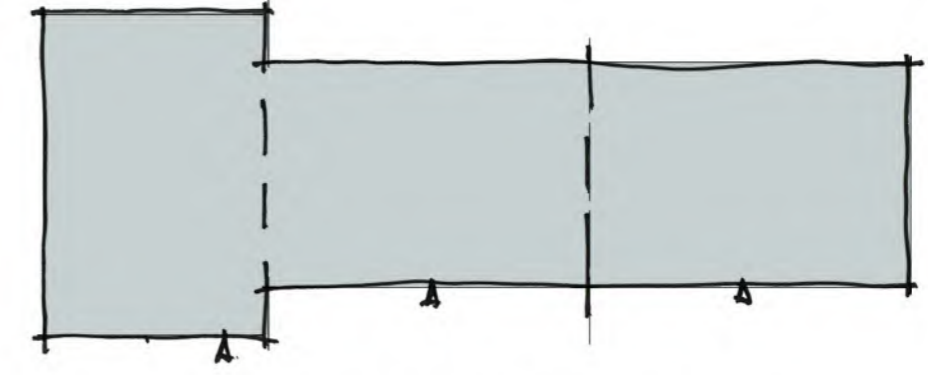

19. Combined shapes (terrace of 3 Max.)  
Bookend one end - corner turner  
narrow/wide frontage combined

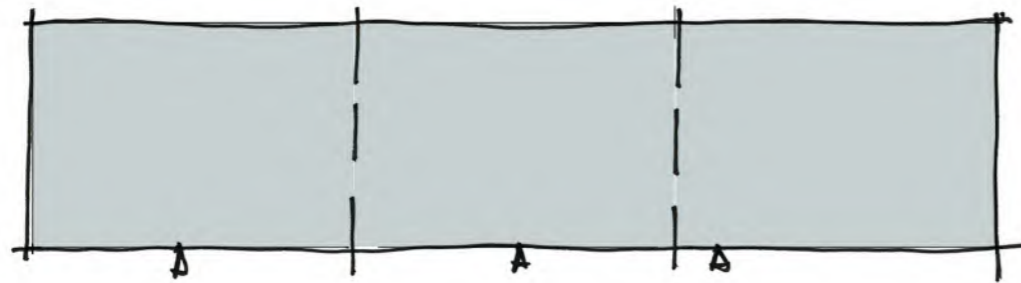

20. Wide frontage only (terrace of 3 Max.) - linear

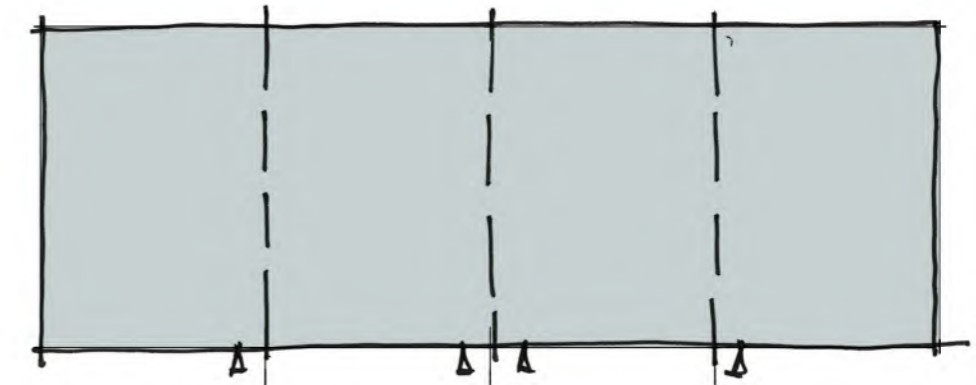

21. Narrow frontage (terrace of 4 Max.) - linear  
Avoid repetition in architecture - handed acceptable

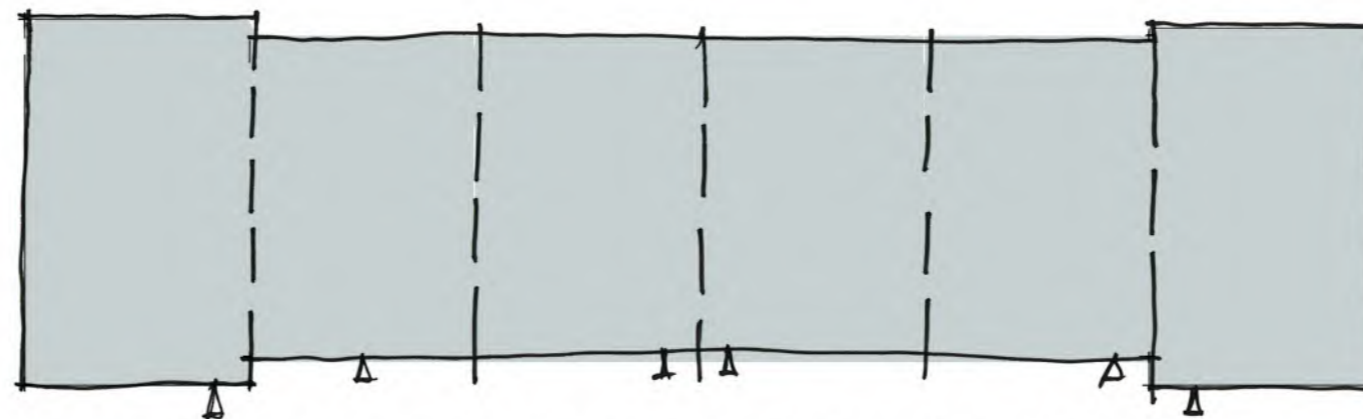

22. -Combined shapes (terrace of 6 Max.) - Bookends on both sides - corner turner  
All narrow frontage - relocating door access to end forms to sides creates wide frontage,  
which is acceptable

8.6.4. ROOF FORMS

Detached forms

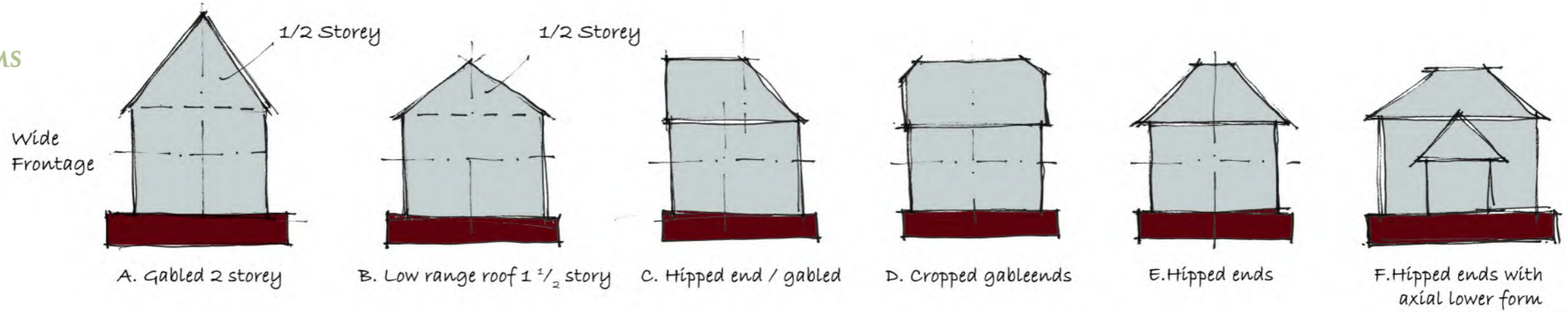

Detached forms -  
Wide and narrow  
frontage

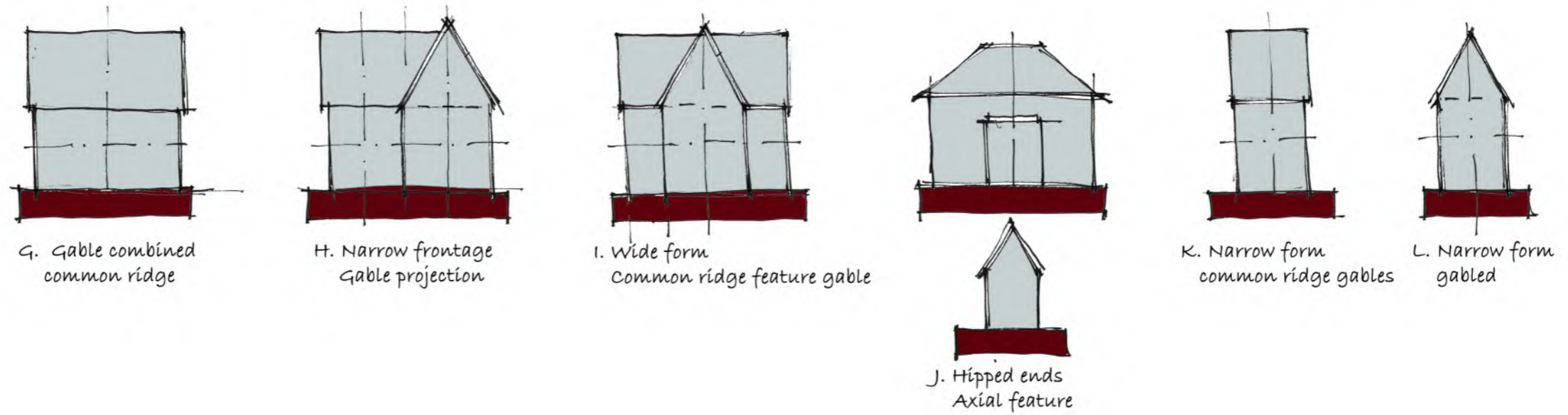

Secondary additions

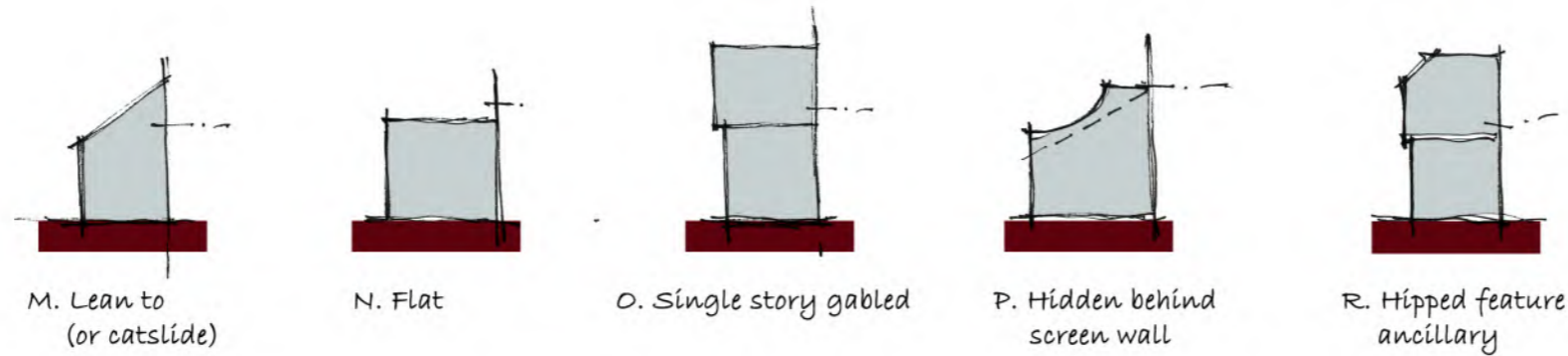

Combined forms  
2 & 3/ 3 1/2 storey units

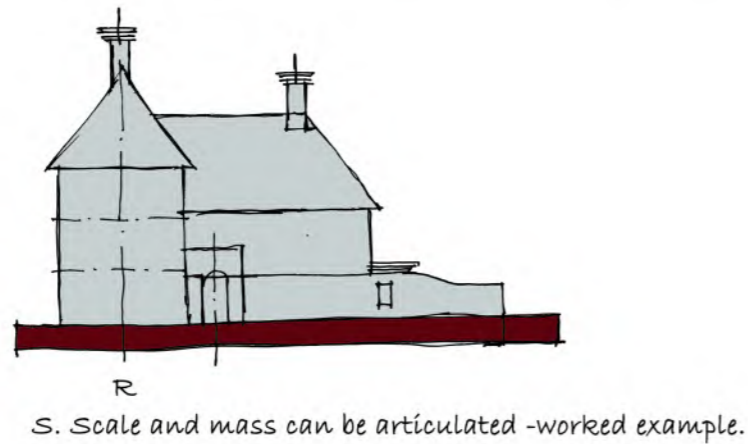



8.6.5. ROOF FORMS - DETAIL

Detached Forms

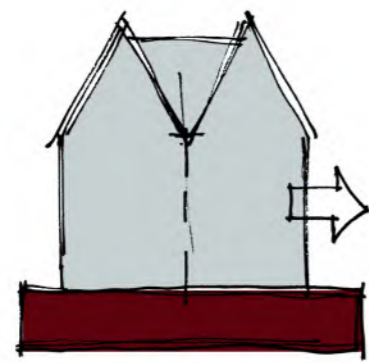

I Double gable and double pile

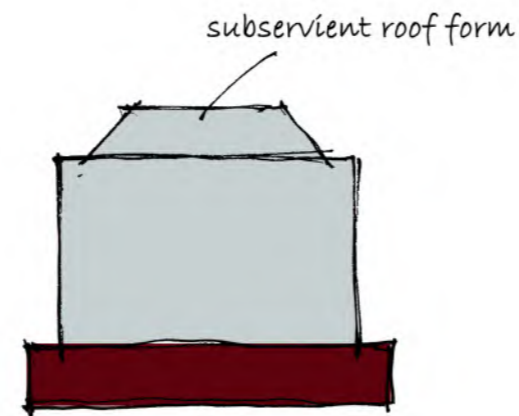

II Parapeted eave, hipped roof

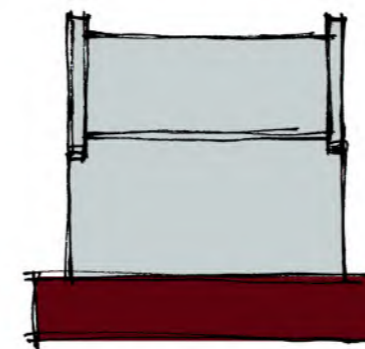

III Parapeted gables, common ridge

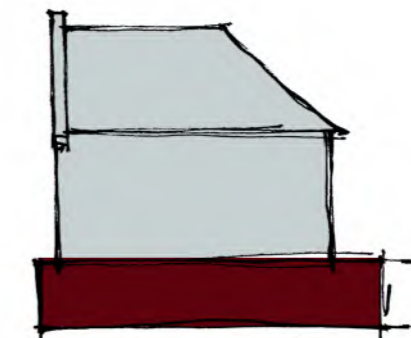

IV Parapeted gable, hipped end Bookend form

Composite Forms

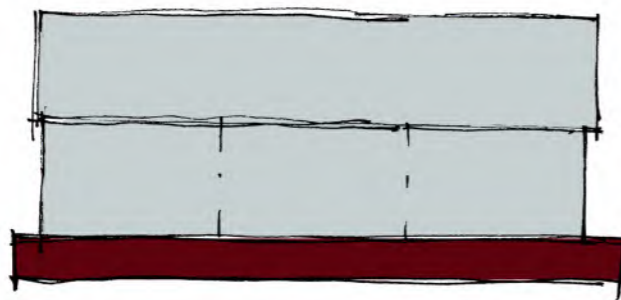

V Wide fronted terrace, common ridge

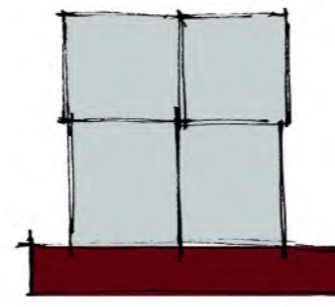

VI Narrow fronted terrace, split plan form

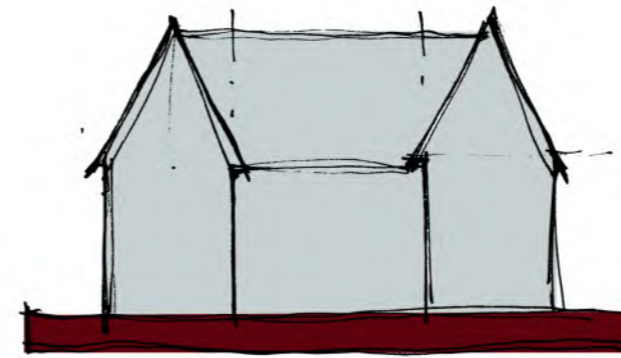

VII Gabled ends, wide / narrow frontage mix Middle ridge lower to heighten bokends

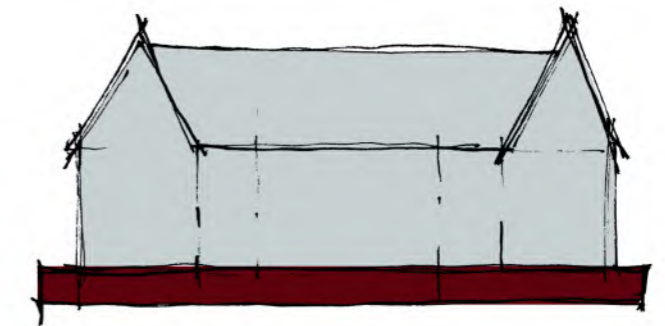

VIII Wide fronted forms, ends with L shaped gable projections from bokends

8.6.6. COMPOSITION OF MASS

The intention of this document is not to stifle or limit creativity. It must however promote creativity and not enable a low design bar to be set where, the mundane or repetition of an architecture, form and use of materials might be available and create a monotony.

Variety is the key, as is hierarchy and connect and as such, this chapter simply sets the ability to use all forms of composition, sampled from the DNA of place and the local vernacular, to sponsor place making principles that have interest, a narrative, reference and subtly.

The formation of any architecture should use a toolkit and creativity and should explore the following in all design formations:

Architectural expression will be a combination of:

- Composition
- Consideration of unity
- Contrast of form and mass
- Element of contrast
- Secondary principles
- Expression of character
- Scale
- Expression of hierarchy/function

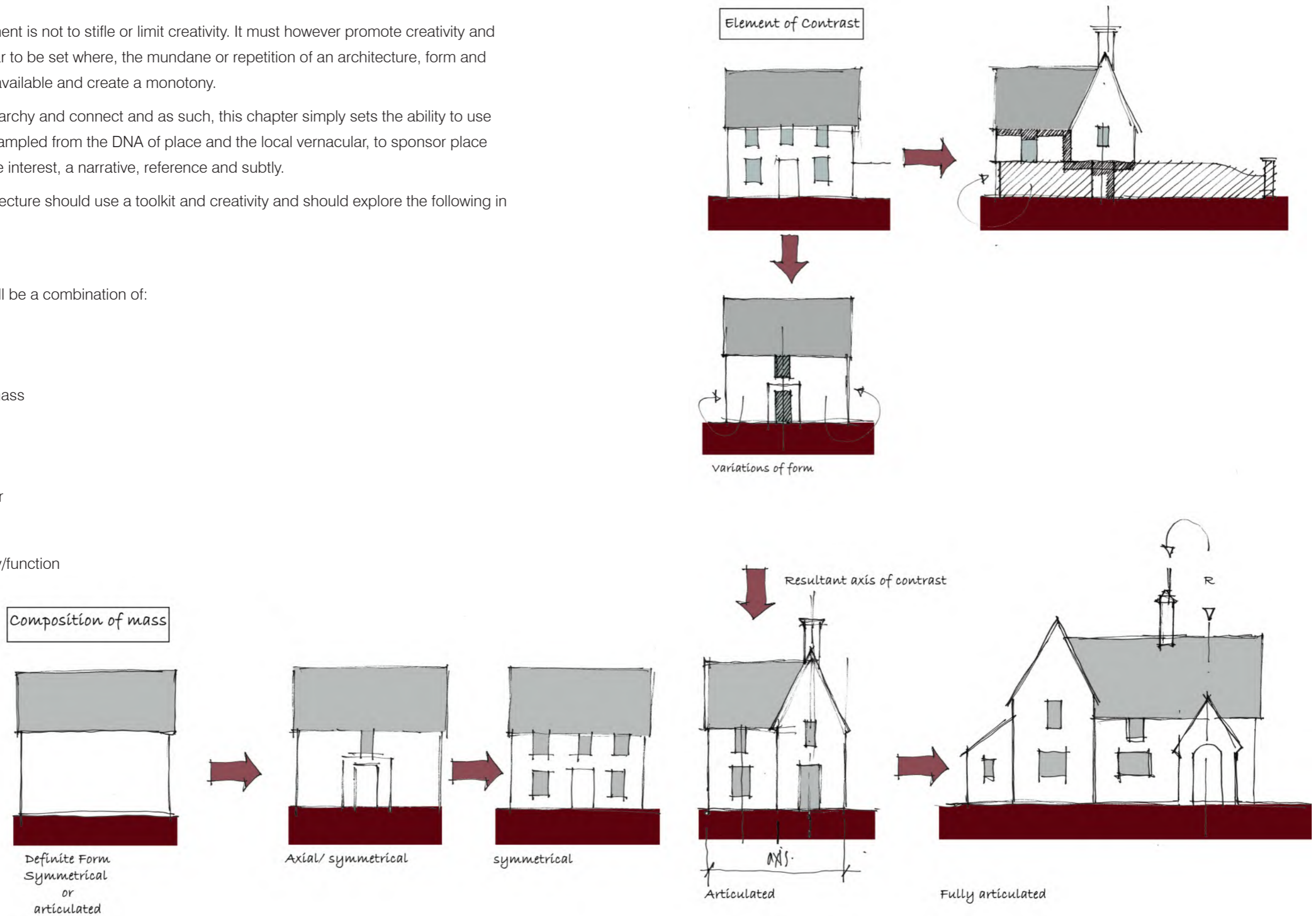

8.6.7. ELEMENT OF CONTRAST



All proposed elevations should possess a complete synergy with the proportions and compositions of actual historic buildings, taken from the exemplar environments. Given is a worked example of a large building within a sample conservation area. The proportions and setting out are considered alongside modelling and materials. It is through this analysis that all proposals should be generated and with cognition of plan form, scale, mass, proportions and composition.

These architectural principles should form the backbone of all built form designs so that the form, narrative, architecture, character of place, use of materials and detail possess synergy with the local vernacular.

The use of such principles should allow fluidity for creativity and a variety of architectural styles but, within the portfolio of the local vernacular traditions. Traditional interpretations are available but always set within the bounds of the vernacular and NOT simple importations which could exist anywhere and everywhere.

Over simplistic boxes with little articulation, modelling, character, over simplistic materials with little display of locally generated craft and dilution of detail should be avoided.

8.6.8. OVERALL BUILDING HEIGHTS (M) AND EAVES HEIGHT (M)

The maximum height of buildings will be 3 ½ storeys. The dominance will be of 2 storeys in a residential scale.

Roof pitches should be traditional and a minimum of 35 degrees to a general maximum of 47.5 degrees. Some isolated steeper pitches which suit the architecture, and which are landmark forms is acceptable in limited areas - see DAS.

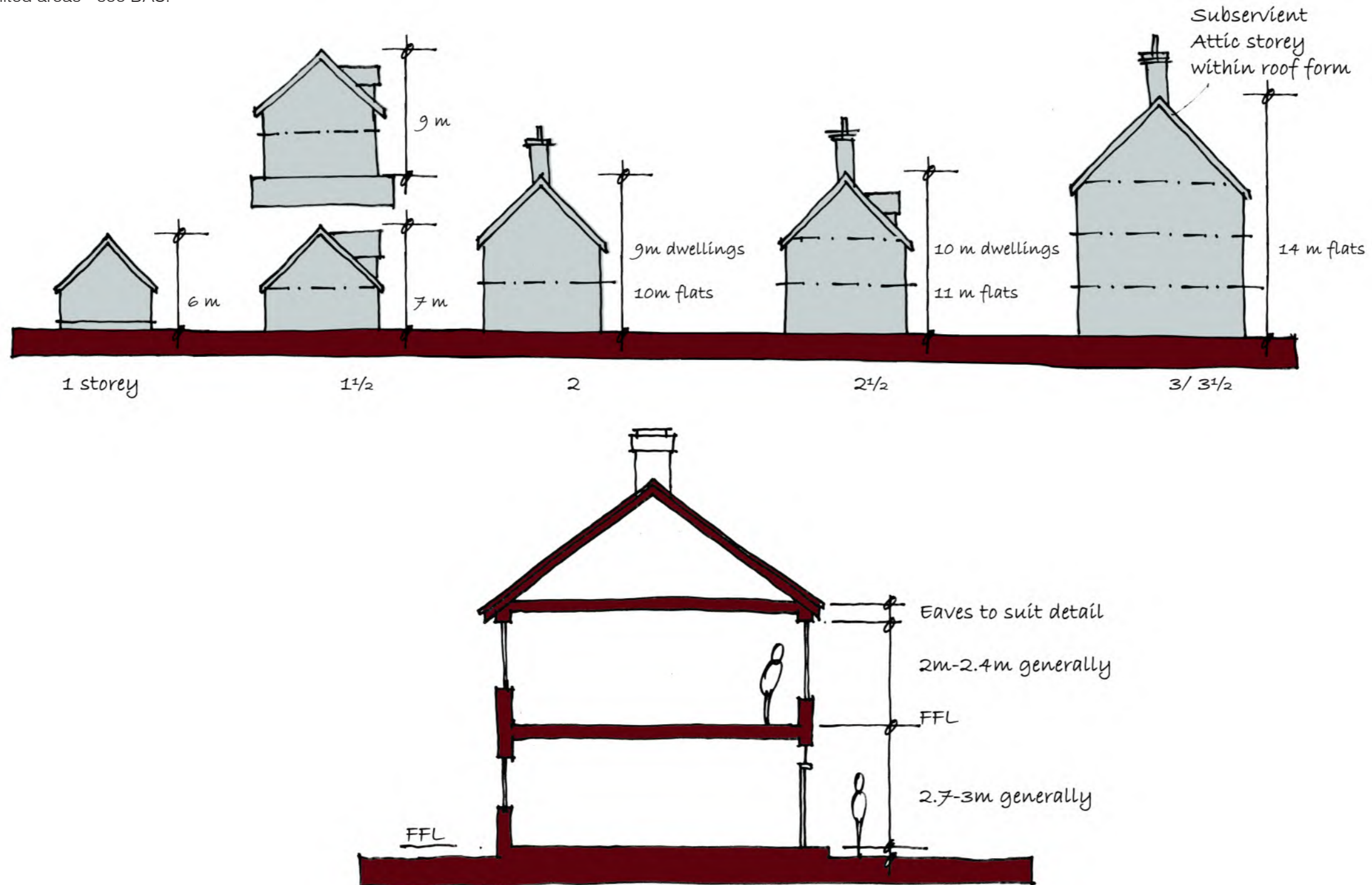

8.6.9. BOUNDARIES

The traditional garden wall can unite the architecture and form a unity. They are a display of craft and should merge with the architecture to be an essential part of the whole and how all is created, composed and merged with the character of the street and relationships to landscape. They should not overly fortify but should be of a human scale and can successfully merge with a building to conceal accommodation beyond. Gateways within can add interest as well as functional need.

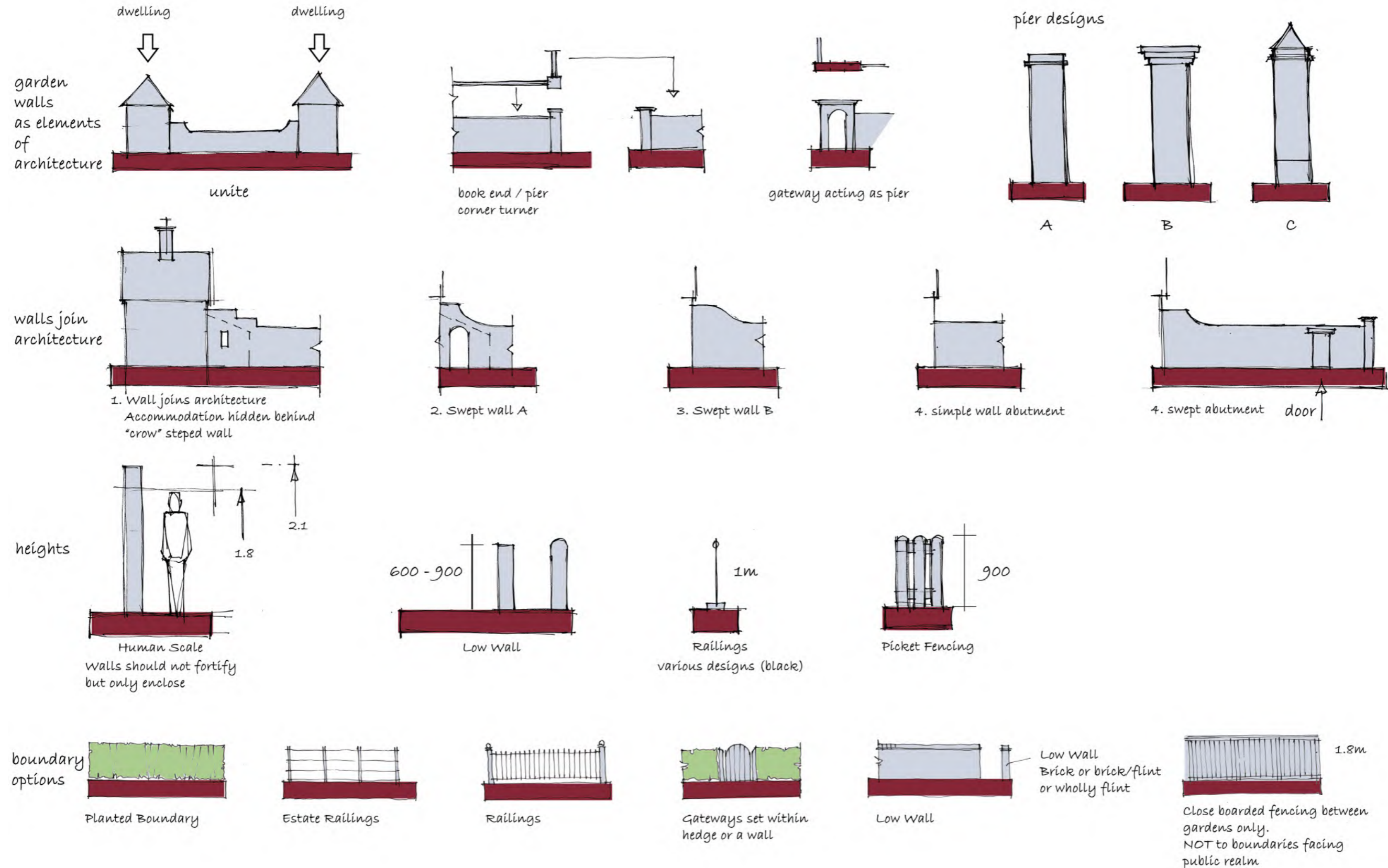

8.7. MATERIALS/DETAILS

Brick

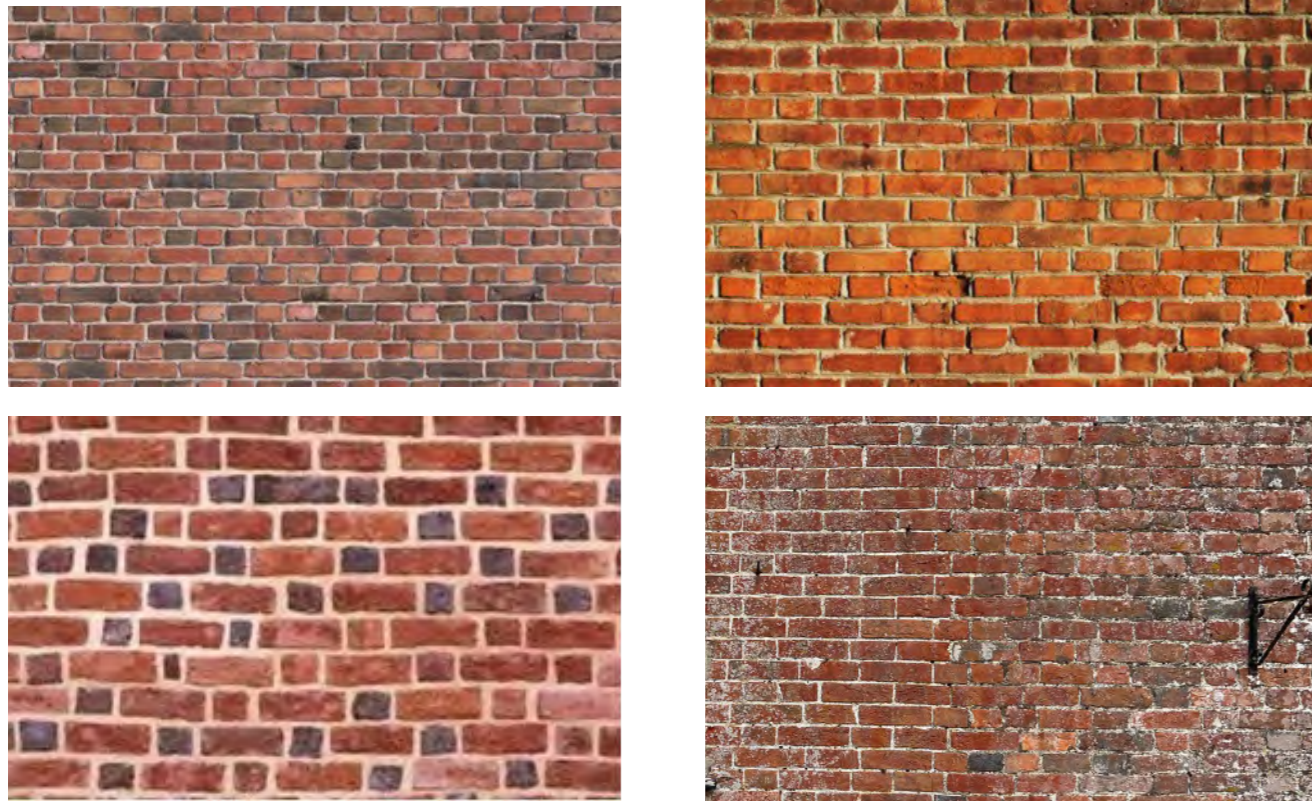

Brick Example - Wimborne St Giles

Painted Brick



Painted Brick Example - Horton

## 8.8. MATERIAL PALETTE

**GARDEN WALL**

Brick selection can be conditioned. Garden walls should generally possess a garden wall bond. Mortar joints should be 1cm max. and be struck back from the arris of the brick.

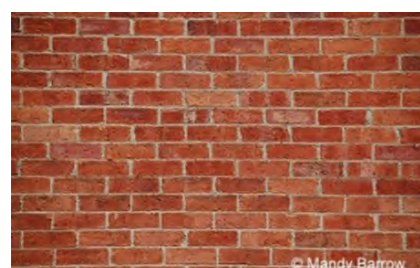
**STRETCHER BOND**

Brick selection can be conditioned. Buildings/structures should generally possess a stretcher bond. Mortar joints should be 1cm max. and be struck back from the arris of the brick.

**EBONY BOARDING TO UPPER STOREY**

Ebony boarding to some upper storeys or within low range subservient structures is acceptable. All should be on counter battens and spaced off the masonry wall below by at least 7.5 cm surface to surface. Barge boards and eaves details within ebony boarding should be stained the same. Use a semi hard wood such as Douglas Fir - NOT a soft wood – details may be conditioned.

**PLAIN CLAY TILE HANGING TO UPPER STOREY**

Plain clay tile hanging to some upper storeys is acceptable. All should be on counter battens and spaced off the masonry wall below by at least 10 cm surface to surface. It should be used sparingly. Details may be conditioned.

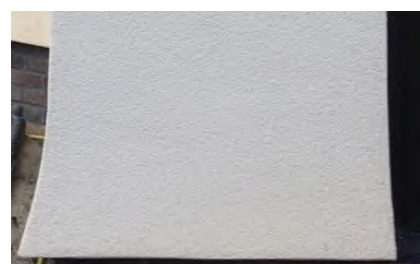
**RENDER**

Render – to whole façade or upper storey. It should be either lime based or a synthetic render such as STO and self-coloured – light ivory. K Rend and cement renders should be avoided. Bell mouths over window heads and at the base should be created using foam formers. All to be conditioned in material and detail.

RENDER

Render may be used on key buildings to create contrast. It should be either lime based or a synthetic render such as STO and self-coloured. It should be of a limited palette of colour with a preference for light ivory. K Rend and cement renders should be avoided. Bell mouths over window heads and at the base should be created using foam formers. All to be conditioned in material and detail.

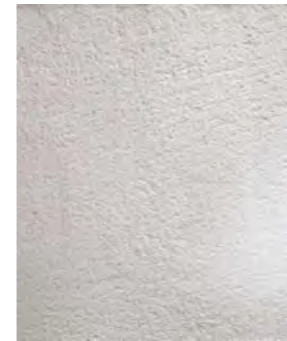

*Render Example - Gussage All Saints*

FLINT

Flint to be used on key buildings only, preferably mixed with red brick detailing. Flint and brick boundary walls can feature throughout.



*Flint Example - Wimborne St Giles*



STONE

Stone can be used as elements: window and door voussoirs, sub cills and porticos etc. Stone can also be used for complete facades, either as dressed stone or as coursed random rubble.



Stone Facade Example - Horton

EBONY BOARDING

High quality, through coloured composite boarding can be used on upper storeys or within low range subservient structures.



Ebony Boarding Example - Horton

8.9. ROOFS

PLAIN TILE

Main roofs to have half round ridges and with bonnets to hipped roofs. Higher status-built forms can have half round hip tiles and occasionally on key buildings.

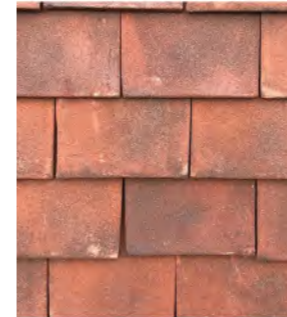

Plain Clay Tile Example - Horton

SLATE

To be natural slate (see materials selection) and generally with half round ridge and hip tiles in terracotta. The tile size and format should be traditional and match the local vernacular, large format should be avoided.



Slate Tile Example - Horton

8.10. DESIGN COMPONENTRY

DORMERS

Occasional presence of pitched roof dormers on houses with rooms in the roof.

In general, the use of dormers within pitched roofs should be to 2 ½ to 3 ½ storey high forms, some 1 ½ storey forms can occur in limited and subservient events within the urban design setting.

Dormer windows should not be bulky additions but should sit subserviently to the main roof form.



*Dormer Window Example - Gussage All Saints*

CHIMNEYS

The relationship between a chimney and roof is a major determinant in the external appearance of a building in vernacular architecture.

Chimneys can be located to form a strong composition. They can punctuate, reinforce symmetry, force a resultant composed effect, or set up rhythms. They can act as “bookends” or sponsor dramatic effect and should be a strong feature and used at will.

The Design Code has been prepared by SWA with input from the whole design team, in a coordinated and holistic design approach, as instructed by the applicant. It fixes certain design elements, and the detail which is considered important to realise the long term vision and quality intent. The code is structured in a logical format to explain the hierarchy and place making principles which should then inform any future Reserved Matters applications.

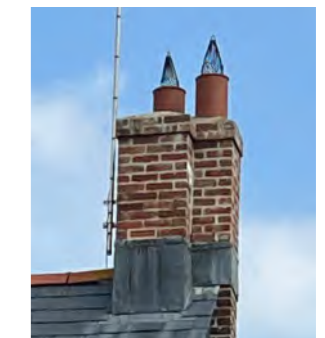
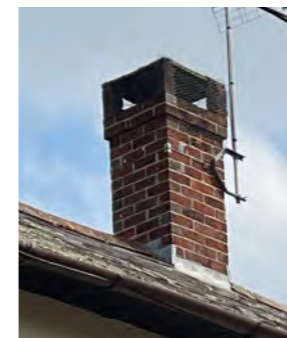
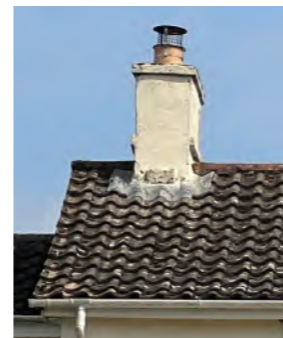

*Chimney Examples From Surrounding Character Areas*

8.11. EXTERNAL WALLS AND ROOF MATERIALS - FULL PALETTE - PROPOSED MATERIAL SCHEDULE

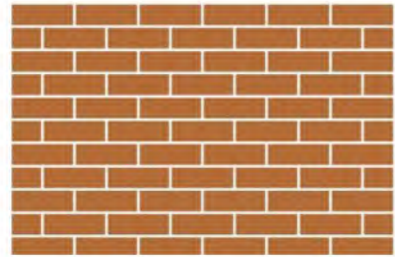

EW01 - Facing brick  
Stretcher bond  
Brick type TBA



Brick 1:  
Quality Multi Brick  
or similar TBA



EW04 - Plain render  
Colour TBA



EW07 -  
Coursed rubble stone  
slip attached to backing block  
Black Mountain

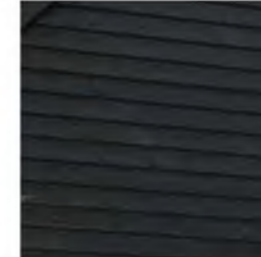

EW10 - Ebony Boarding  
Black/Dark Grey

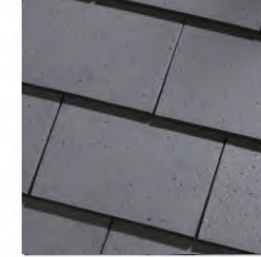

RM01 -  
Clay roof tile  
Colour & type TBA  
Slate colour



RM04 -  
Clay roof tile  
Colour & type TBA

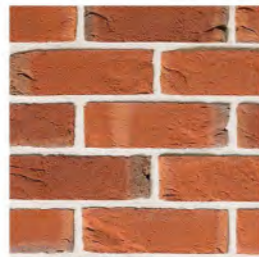

Brick 2:  
Quality Red Brick



EW05 - Stucco/course  
render  
Colour TBA

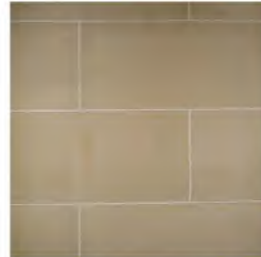

EW08 - Dressed stone/  
Ashlar  
Colour TBA



EW11 -  
Tile hanging  
Colour & type TBA

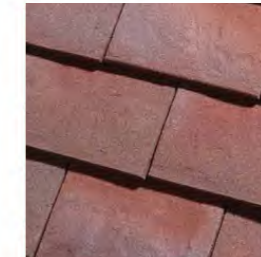

RM02 -  
Clay roof tile  
Colour & type TBA



RM05 - Natural Slate  
Colour & type TBA



Brick 3:  
Quality Buff Brick  
or similar TBA



EW06 - Rough cast  
render  
Colour TBA



EW09 - Flint Wall

8.12. INDICATIVE HOUSE TYPES USING LOCAL VERNACULAR- 2, 3, 4 & 5 BED MIX



2 bedroom semi detached house



3 bedroom house



3 bedroom house



3 bedroom semi detached house - Lady Wimborne Cottage



3 bedroom semi detached house



4 bedroom house



4 bedroom house



5 bedroom house



2 bedroom semi detached house



4 bedroom house



4 bedroom house



3 bedroom house



3 storey apartment block with individual access to ground floor dwellings



Street elevation of 4 bedroom house and 3 bedroom semi detached dwellings



4 bedroom house



4 bedroom house





*3 bedroom house*



*3 bedroom house*



*3 bedroom house*

8.13. KEY PLAN OF THE CAMEO VIEWS



8.14. KEY PLAN OF THE CAMEO VIEWS 1 & 2



8.15. KEY PLACE 1



8.16. KEY PLACE 2



8.17. KEY PLAN OF THE CAMEO VIEW 3



8.18. KEY PLACE 3



8.19. KEY PLAN OF THE CAMEO VIEW 4





8.20. KEY PLACE 4



8.21. KEY PLAN OF THE CAMEO VIEW 5



8.22. KEY PLACE 5



8.23. KEY PLAN OF THE CAMEO VIEW 6



8.24. KEY PLACE 6



8.25. KEY PLAN OF THE CAMEO VIEW 5

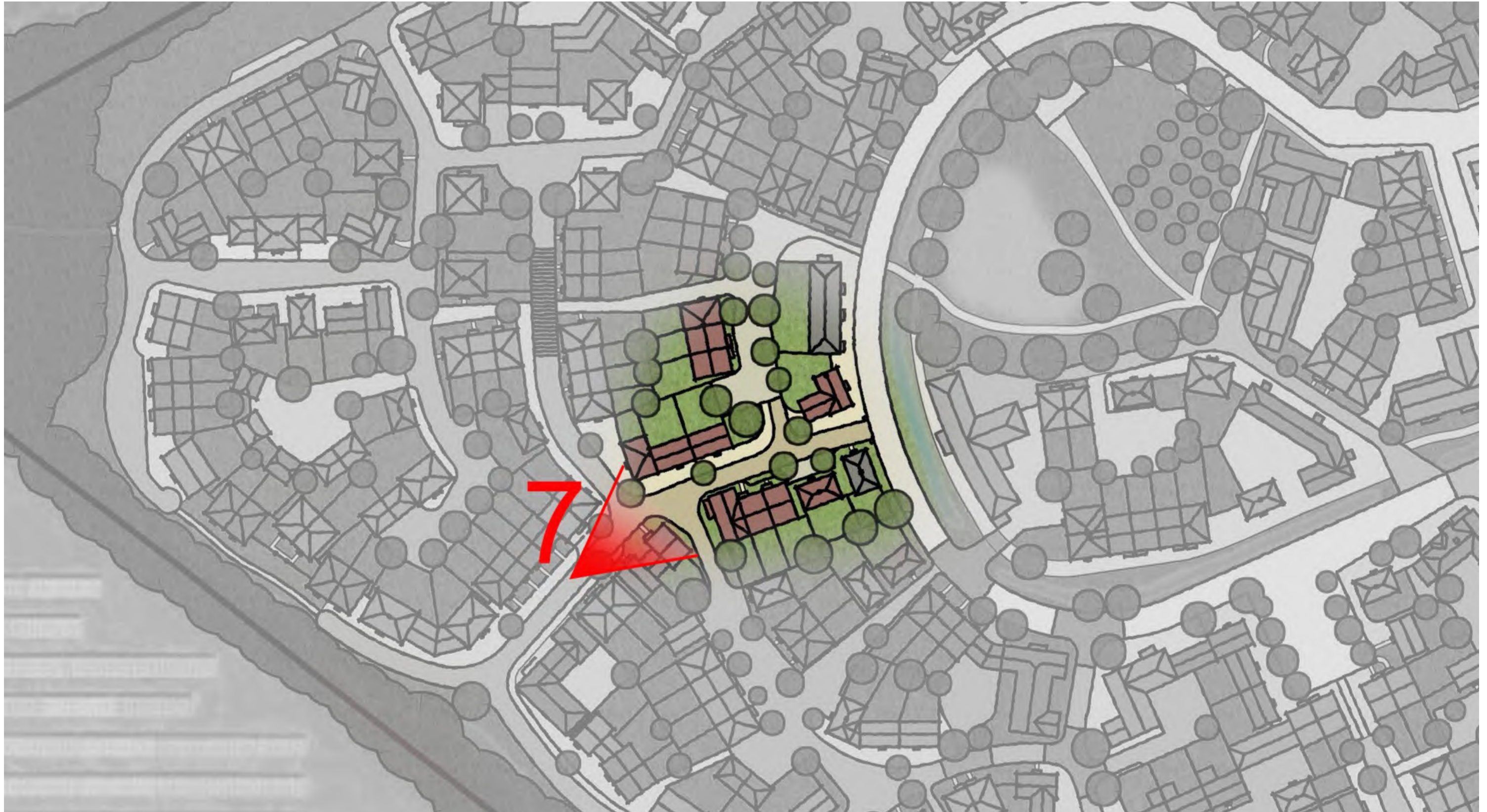

8.26. KEY PLACE 7



## SECTION 9 - CONCLUSION

It is often the dilemma of local and central government that, in meeting the need for quantum, how can quality be also integrated so that quantum, community, quality, facility, use and function all reside together?

Quality, is not limited to or direct measure of materials or architectural component alone, but of place making principles which are, far reaching.

This is the common dilemma that has characterised much of our need for housing since post war years and the very need for Town Planning & Urban Design to emerge as professions.

The DAS analyses context and all inputs to arrive at parameters. The components of the parameters and the “parts” that join to create a whole are very much at the initiative of our client, to present facility, function, use and community WITH a high bar in design quality that is clear.

The design quality of "Alderholt Meadows" and, what it can become in its architecture, place making, urban design and materials, is explored in detailed within this code.

This quality is not limited to “bricks and mortar”, this quality extends through the thread of all its facility, enhancement, function, community, leisure, and sports that are far reaching, and which might add to the quality of all.

Quality and code can embrace community and place making principles, but a code can also embrace legacy, connectivity, and wider supports to the facility of a place and community which exists. This is the very reason why S.106 contributions and then CIL have emerged as a plan for some relationship between new homes and community however, this is because piecemeal development cannot add or invest and so mechanisms had to be created.

It is the case that good design enhances the character and quality of place. Good design can add to community and create new housing opportunities, employment and places for amenity that did not previously exist.

This creation will create much needed new homes but, also community facilities to meet community needs and benefit all.

Design is an investment. It is an investment in a quality of place that can enhance the whole community in terms of lifestyle, function, employment, facilities, and enjoyment.

As such, this offer achieves an agenda that a conventional piecemeal housing delivery system has often struggled to allow or manage and, all set with a code and vision which is clear, controllable and with quality, character and key place making principles.

This code sets a high design bar and, If consented offers a place which can grow with the Local Planning Authority and, the existing Alderholt community to become a combination that is far greater than the sum of its parts.



SCOTT WORSFOLD ASSOCIATES LTD.

T: 01202 580902 A: The Studio | 22 Ringwood Road | Longham | Ferndown | BH22 9AN January 2023